

*To become the Innovation Engine of Motion Control*

**MOTION CONTROL PRODUCTS CATALOGUE** (STEPPER SYSTEM)



MOTION CONTROL PRODUCTS CATALOGUE

Shenzhen Rtelligent Technology Co.,Ltd

+86(0)755-27440012 / +86(0)755-27440023

info@rtelligent.cn / info@szruitech.com

website : www.rtelligentglobal.com

5F,Building A,Rtelligent Technology Park,Xingyu Road,Xixiang,Bao'an District,Shenzhen,China



## About Us

Shenzhen Rtelligent Technology Co., Ltd., located in Shenzhen, China, is a national high-tech enterprise dedicated in R & D, marketing and sales of high performance motion control products based on latest control technologies.

Since its establishment in 2015, the management has been focusing on the field of industrial automation. Our main products include servo system, stepper system, motion control card, etc., which are widely used in high-end intelligent manufacturing industries such as 3C electronics, new energy, logistics, semiconductor, medical, CNC laser processing, etc.

Rtelligent adheres to deeply understand and meet customer demand, always takes reliable quality and leading technology as its core competitiveness, attaches great importance to and continuously increases R&D investment. At present, it has more than 60 patents for invention, utility model, copyright, trademark information, etc; The products have passed CE and other product quality & safety certification.



Founded in **2015**



**60+**

Core Technology Patents

**2** Major production bases



**70+**

Sales Countries And Regions

**30+** Offices in China



**100+**

Distributors



**10000+**

Sales Customers



**5million+**

Stepper Servo Sales Volume

**Vision**  
To become the Innovation Engine of Motion Control

**Mission**  
Precisely Drive Industry, Efficiently Empower the Future

**Values**  
Customer First · Unity and Collaboration  
Pioneering Innovation · Striving for Shared Success

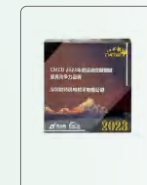
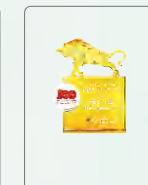

P05 ES Series Bus-type Stepper Drive

P13 EC Series Bus-type Stepper Drive

P15 NT Series Integrated Stepper Drive

P17 New Generation of Stepper System S Series

P19 T-S Series Closed Loop Pulse Control Stepper Drive

P23 Closed Loop Steppr Drive T Series

R-S Series Open Loop Pulse Control Stepper Drives P25

R Series Stepper Drive P29



# CONTENTS

Reducer for Stepper Motor P61

Integrated Stepper Motor IR/IT Series P63

Bus Stepper Integrated Motor P69

Linear Stepper Motor P73

Matching Cables P76

Quick Selection Table P77

P31 Multi-axis Stepping System

P33 IO Control and Potentiometer Speed Regulating Stepper System

P35 5 Phase Stepper System

P39 Closed Loop Stepper Motor Series

P45 Open Loop Stepper Motor



# Motion Control System Solutions Map





# ES Series

## Bus-type Stepper Drive

Upgraded version

- EtherCAT
- PROFINET
- EtherNet/IP



### Naming Rule



① Bus-type	③ T: closed loop	④ Matching motor frame size
② S upgraded version		⑤ Default: single-axis X2: Dual-axis X4: Four-axis

\*Model naming rules are only used for model meaning analysis. For specific optional models, please refer to the details page.

## Product Parameter

Model	EST60
Bus protocol	available for option
Voltage range	20-80VDC, 18-50VAC
Output current	0.5~6.0A
Matching motor	stepper motor below Nema 24
Control mode	open-loop control, closed-loop control
Photoisolated input	4 common-anode 24V inputs
Photoisolated output	2 photoelectric isolation output: alarm, in place and universal output
Encoder resolution	0-65535
Communication interface	double RJ45
Brake interface	No additional relay control is required
Debugging interface	Type-C

## Installation Dimension

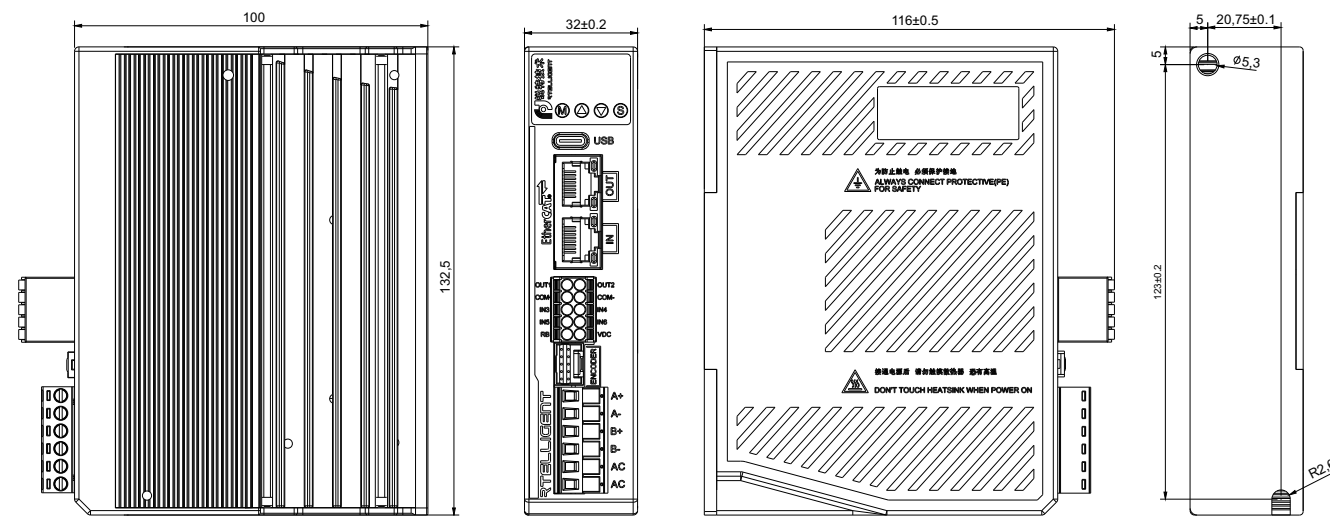

## Port Distribution

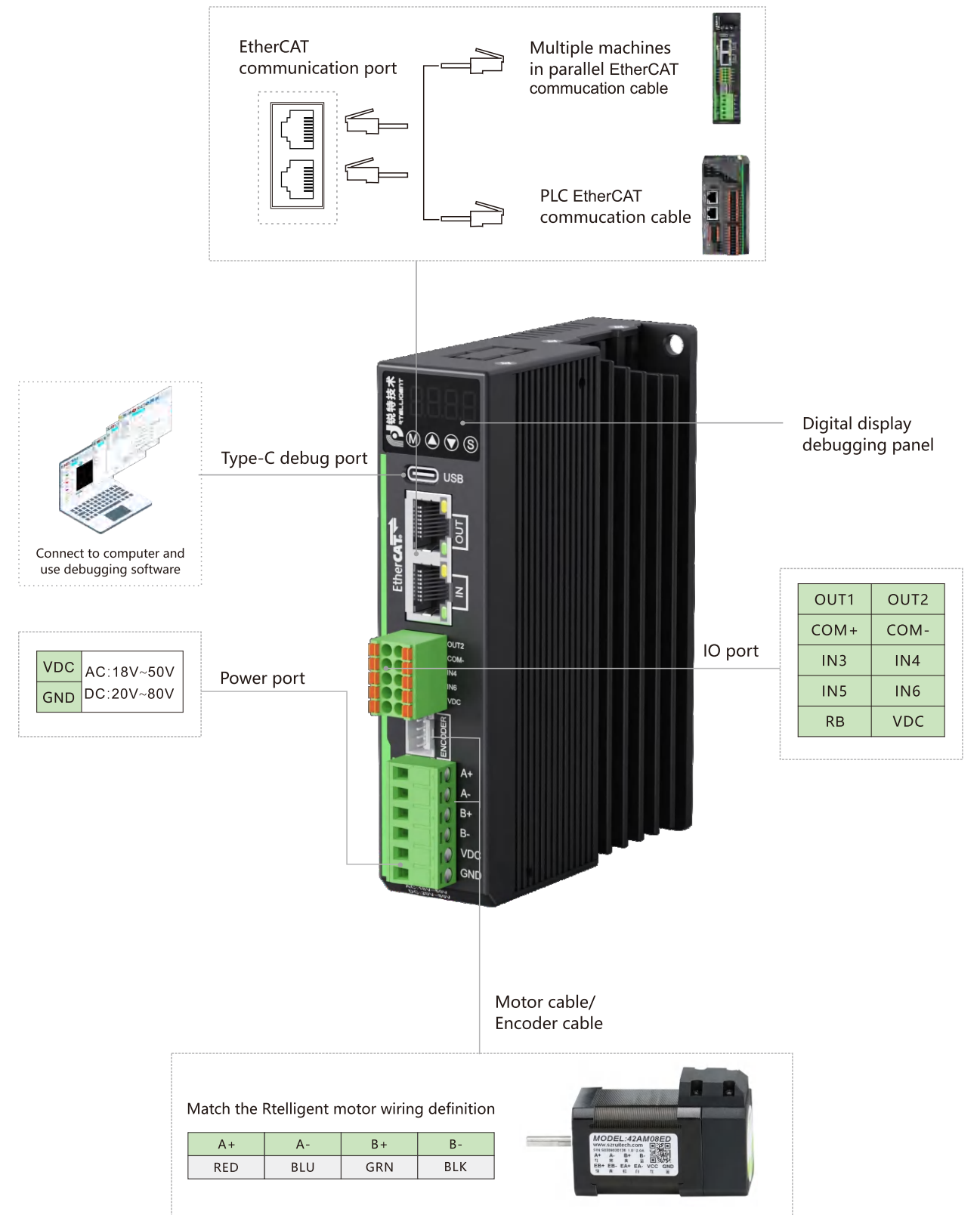

## Product Parameter

Model	EST60X2
Bus protocol	EtherCAT
Voltage range	20-80VDC, 18-50VAC
Output current	0.5~6.0A
Matching motor	stepper motor below Nema 24
Control mode	open-loop control, closed-loop control
Photoisolated input	8 common-anode 24V inputs
Photoisolated output	4 photoelectric isolation output: alarm, in place and universal output
Encoder resolution	0-65535
Communication interface	double RJ45
Brake interface	No additional relay control is required
Debugging interface	Type-C

## Installation Dimension

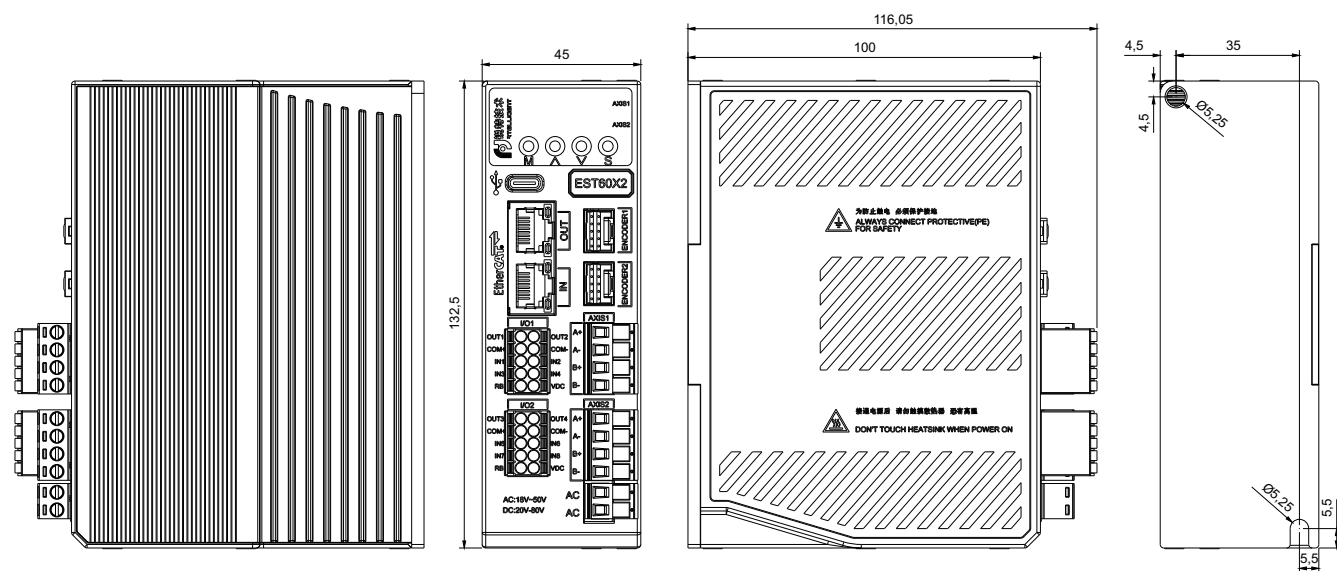

## Port Distribution

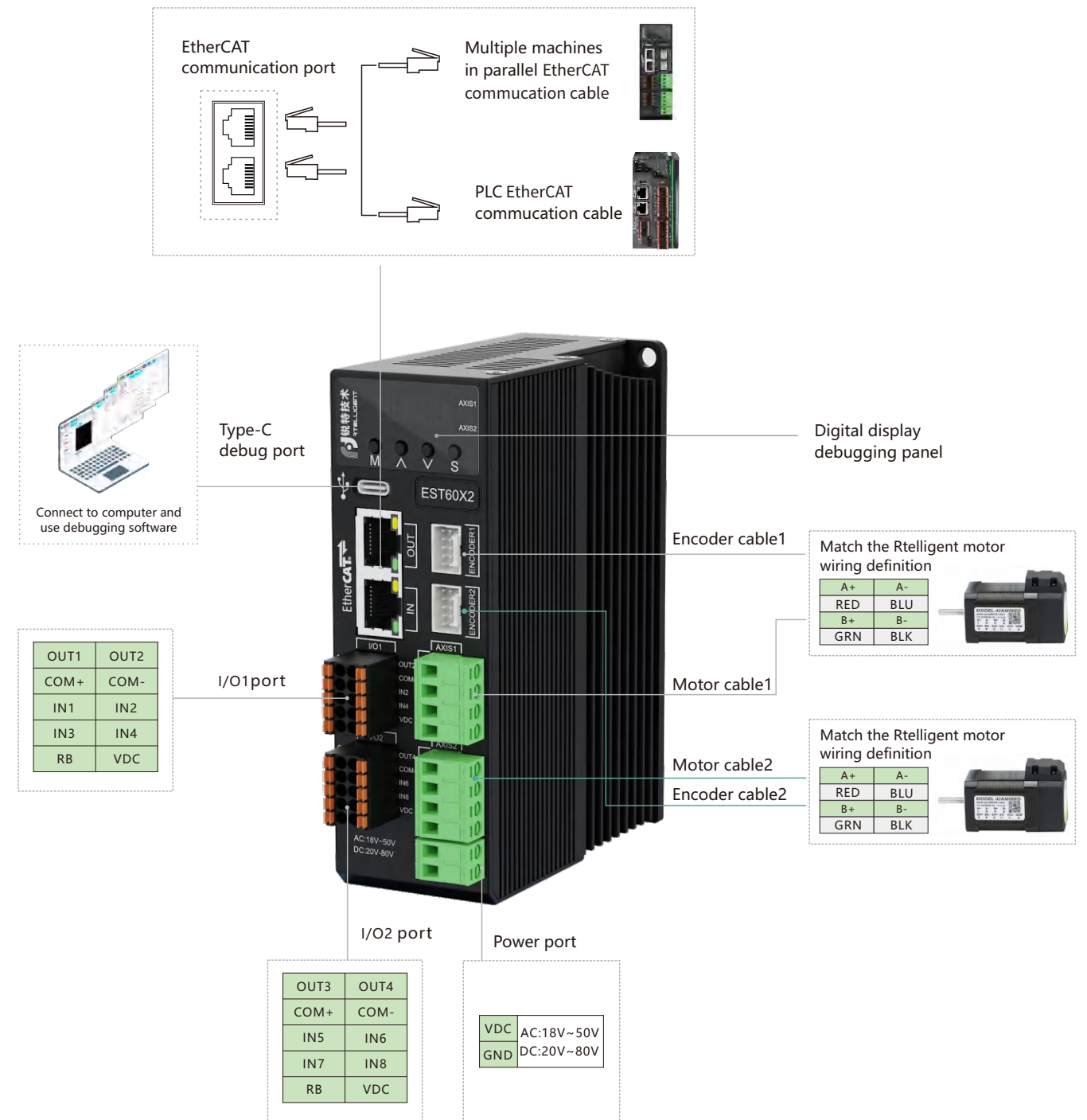

## Product Parameter

Model	EST60X4
Bus protocol	EtherCAT
Voltage range	20-80VDC
Output current	0.5~6.0A
Matching motor	stepper motor below Nema 24
Control mode	open-loop control, closed-loop control
Photoisolated input	16 common-anode 24V inputs
Photoisolated output	4 photoelectric isolation output: alarm, in place and universal output
Encoder resolution	0-65535
Communication interface	double RJ45
Brake interface	No additional relay control is required
Debugging interface	Type-C

## Installation Dimension

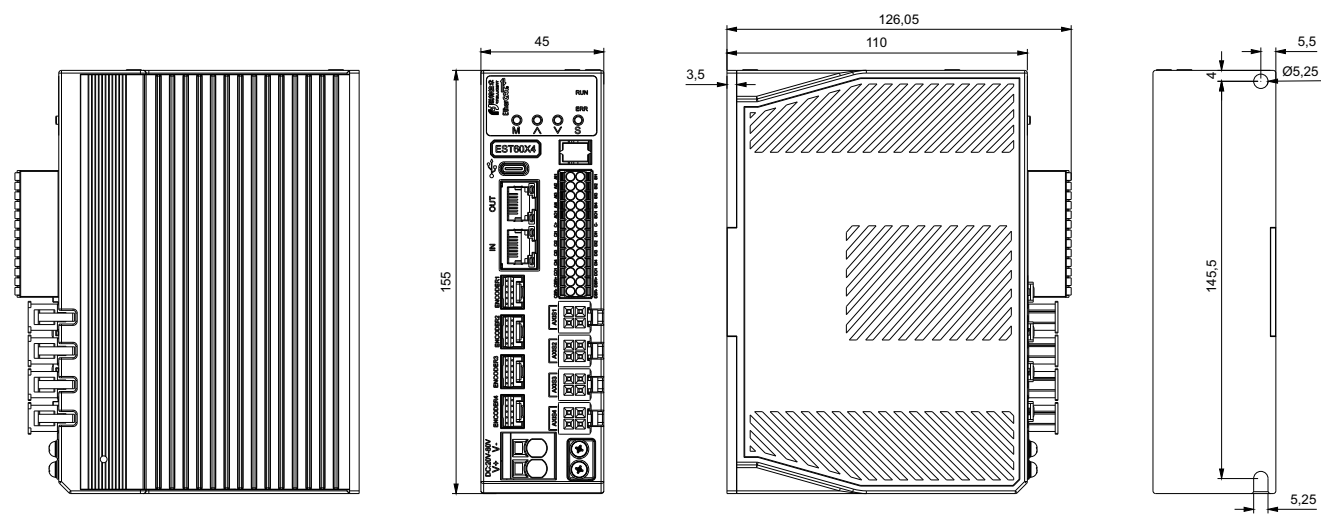

## Port Distribution

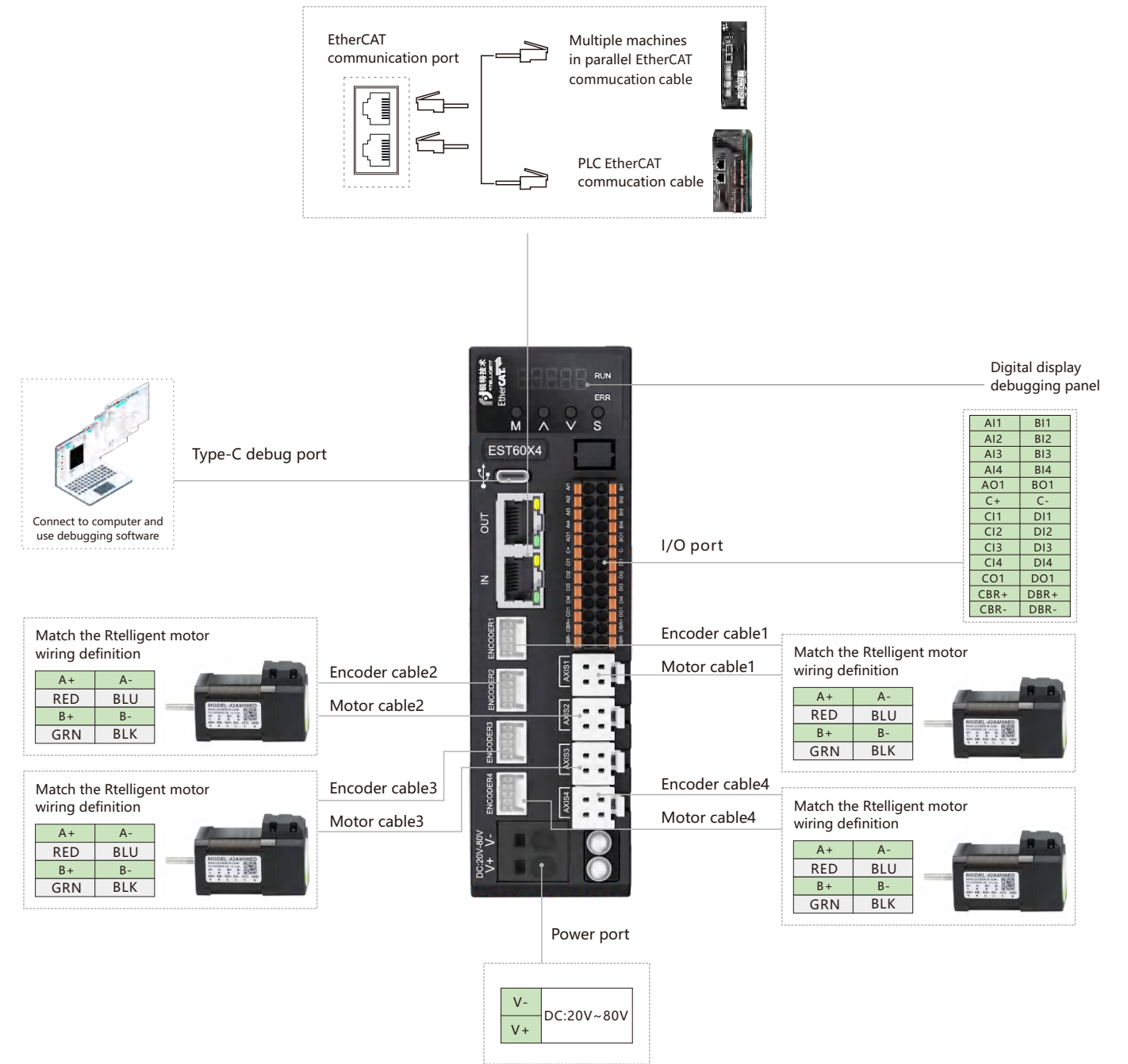

# EC Series Bus-type Stepper Drive

Rtelligent EC Series Economical EtherCAT Bus Stepper Drive, based on the CoE (CANopen over EtherCAT) standard framework, complies with the CiA402 standard. With a data transmission rate of up to 100 Mb/s, it supports linear, ring, and other network topologies. The product lineup includes single-axis, dual-axis, two-in-one, and multi-axis integrated types to meet the demands of various working conditions.



01  
matching motor  
frame below 86

02  
Comply with the  
CiA402 specification

03  
Support multiple  
internal homing

04  
The synchronization  
period is 500µs

05  
Support CSP/CSV/HM  
/PP/PV control mode

06  
Support multi axis

## Naming Rule

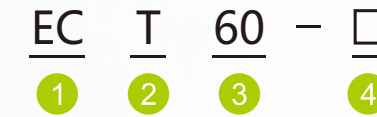

1 Fieldbus type N: 485 communication EC: EtherCAT communication	2 R: open loop T: closed loop
3 Matching motor frame size	4 Non-standard code

\*Model naming rules are only used for model meaning analysis. For specific optional models, please refer to the details page.

## Technical Specifications

Model	Peak current A	Weight kg	Input voltage	Dimensions mm	Input and output	Matching motor
ECR42	6.0	0.4	18-80VDC	132×82×29	Six inputs, two outputs	open loop below 42mm
ECR60	6.0	0.4	18-80VDC	132×82×29	Six inputs, two outputs	open loop below 60mm
ECR86	7.2	0.6	18-80VAC	151×97×35	Six inputs, two outputs	open loop below 86mm
ECT42	6.0	0.4	18-80VDC	132×82×29	Four inputs, two outputs	closed loop below 42mm
ECT60	6.0	0.4	18-80VDC	132×82×29	Four inputs, two outputs	closed loop below 60mm
ECT86	7.2	0.6	18-80VAC	151×97×35	Four inputs, two outputs	closed loop below 86mm
ECR60X2A	6.0	0.5	18-80VDC	175×98×33	Eight inputs, four outputs	open loop below 60mm
ECT60X2	6.0	0.5	18-80VDC	175×98×33	Eight inputs, four outputs	closed loop below 60mm

## General Master Stations Supported



# NT Series Integrated Stepper Drive

The NT series stepper drive integrates intelligent motion control functions. Combined with external IO control, it can achieve functions such as constant speed, positioning, multi-segment position, and automatic homing.

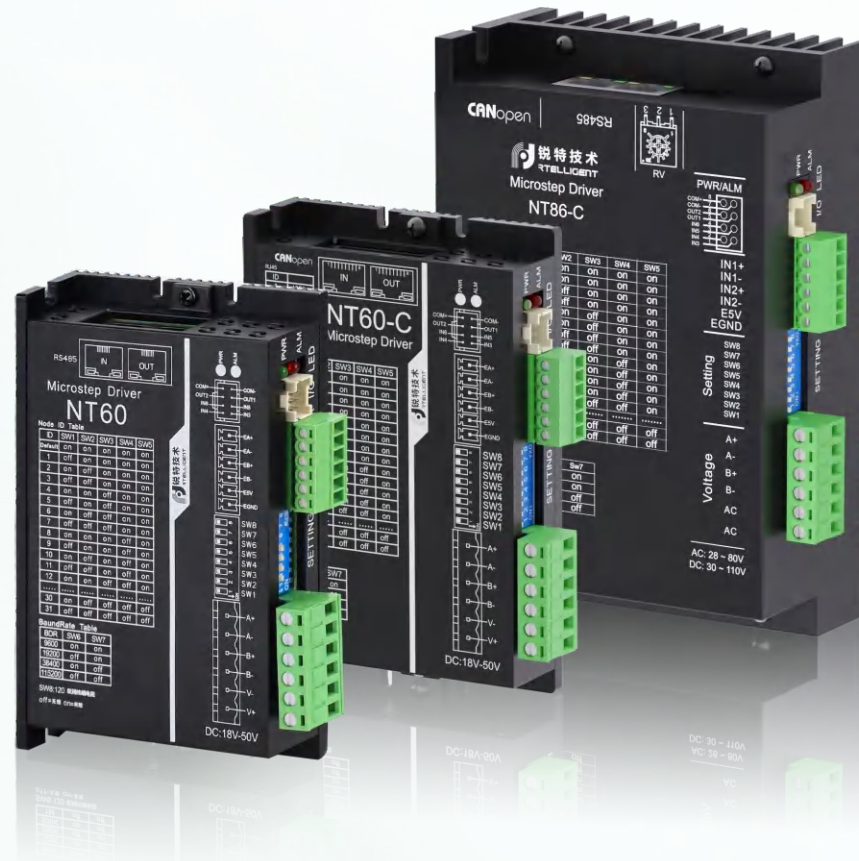

## Naming Rule

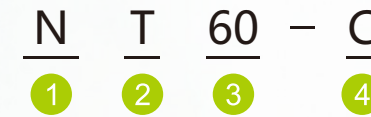

1 Fieldbus type  
N: integrated drive & control

2 Series code  
T: with encoder interface

3 Matching motor frame size

4 Non-standard code  
C: CANopen

\*Model naming rules are only used for model meaning analysis. For specific optional models, please refer to the details page.

## Basic Spec of RS485 Communication Drive

Model	Peak current A	Weight kg	Power voltage	Dimensions mm	Communication mode	Maximum baud rate	Matching motor
NT60	6	0.3	18-50VDC	118×76×33	485	115200	Open loop or closed loop below 60mm
NT86	8	0.6	18-80VAC	151×97×52	485	115200	Open loop or closed loop below 86mm

## Basic Spec of CAN Communication Drive

Model	Peak current A	Weight kg	Power voltage	Dimensions mm	Communication mode	Maximum baud rate	Matching motor
NT60-C	6	0.3	18-50VDC	118X76X25	CANopen	1Mbps	Open loop or closed loop below 60mm
NT86-C	8	0.6	24-110VDC	151X97.5X52	CANopen	1Mbps	Open loop or closed loop below 86mm

## How to Use

PLC Master Station + NT Drive Slave Station

Touch Screen Master + NT Drive Slave

### Automatic Programming Mode

IO positioning operation

IO forward and reverse  
One or more target position  
Support torque homing

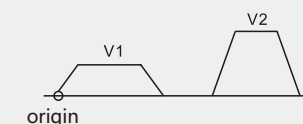

IO torque mode

IO forward and reverse  
Target torque switching  
Support torque homing

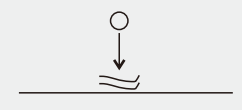

IO speed control operation

IO forward and reverse  
One or more target position

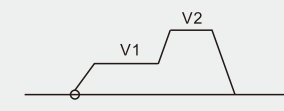

IO torque mode

IO forward and reverse  
Target torque and position switching  
Support torque homing

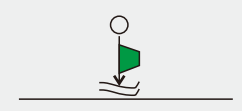

01 Matching motor frame below 86

03 Communication control

05 Switch control

02 Integrates the function of motion controller

04 Support multiple internal homing

06 Supports up to 31 slave stations

Upgraded version

# New Generation of Stepper System S Series

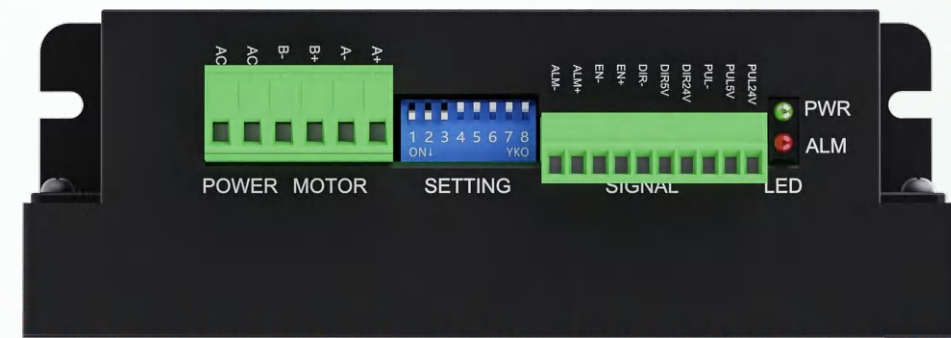
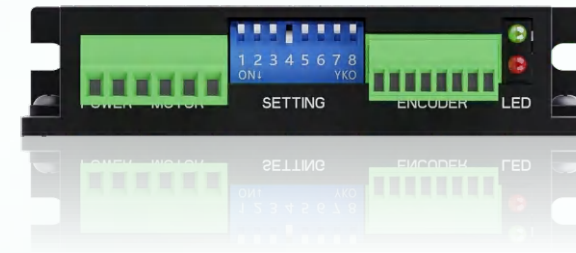
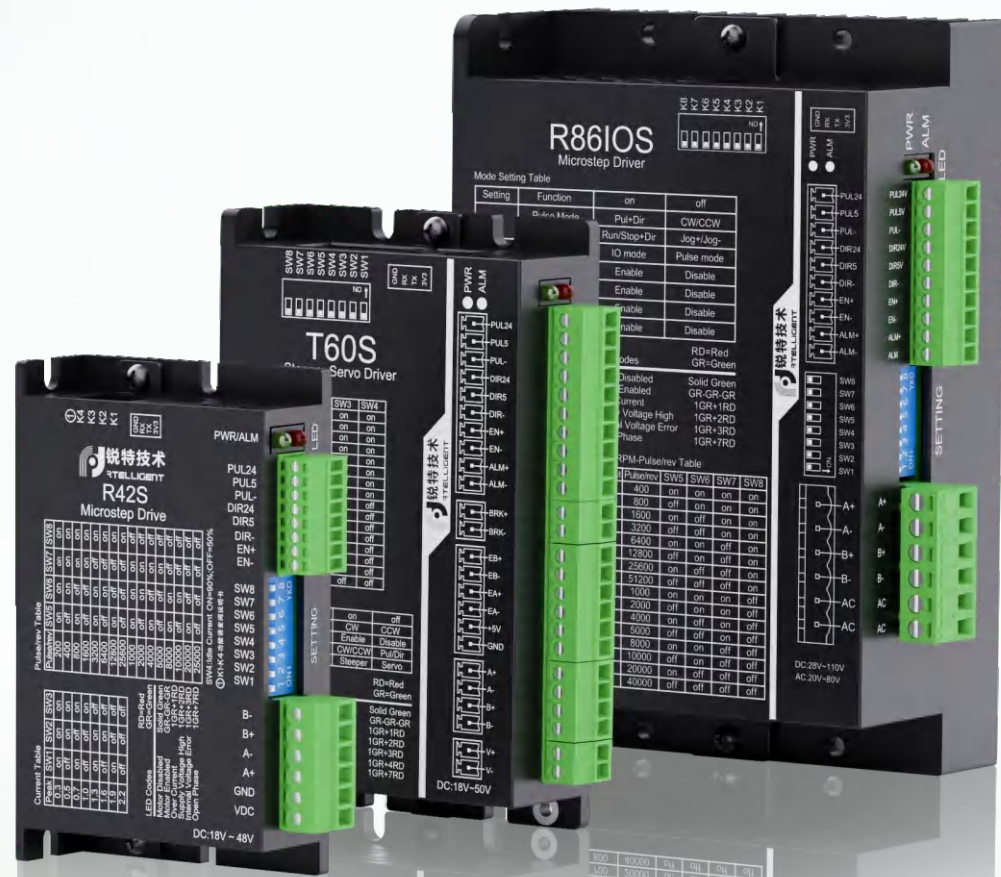

### Naming Rule



- |   |                             |
|---|-----------------------------|
| ① R: open loop<br>T: closed loop                                      | ② Matching motor frame size |
| ③ IO: switch control<br>IR: potentiometer type<br>Default: pulse type | ④ Upgraded version          |

\*Model naming rules are only used for model meaning analysis. For specific optional models, please refer to the details page.

# T-S Series Closed Loop Pulse Control Stepper Drives

T-S series is an upgraded version of the closed-loop stepper driver launched by Rteelligent and the product design idea is derived from the company's accumulation in the field of stepper drive for many years. With a new architecture and algorithm, the new generation of stepper drive effectively reduces the low-speed resonance amplitude of the motor, has a stronger anti-interference ability, while supporting sensorless stall detection, phase alarm, lock output and other functions, support a variety of pulse command forms, multiple dip setting functions.



**01**  
Auto tuning

**02**  
Low speed  
vibration suppression

**03**  
Sensorless stall detection

**04**  
PUL+DIR/CW+  
CCW/QEP

**05**  
Multiple dip setting

**06**  
Brake output

**07**  
Missing phase alarm

**08**  
5V/ 24V pulse  
command independent

## Product Parameter

Model No.	T42S	T60S	T86S
Product Photo			
Voltage range	18~50VDC	18~50VDC	28~110VDC
AC input	Non suport	Non suport	20~80VAC
Current range	2000mA	6000mA	8000mA
Matching motor	Closed loop motor below 42mm	Closed loop motor below 60mm	Closed loop motor below 86mm
Brake interface	Directly connect the brake wire		
Debugging interface	Serial port TTL3.3V		
Extended dip	8 Bit		
Alarm output	1		
Pulse command voltage	5V/24V independent port		
Pulse width setting	Software setting		
Direction inversion	Dip setting		
Instruction filter	Dip setting		
Pulse mode setting	PUL+DIR/CW+CCW dip setting		
working mode	Open loop/Closed loop dip setting		

## Installation Dimension

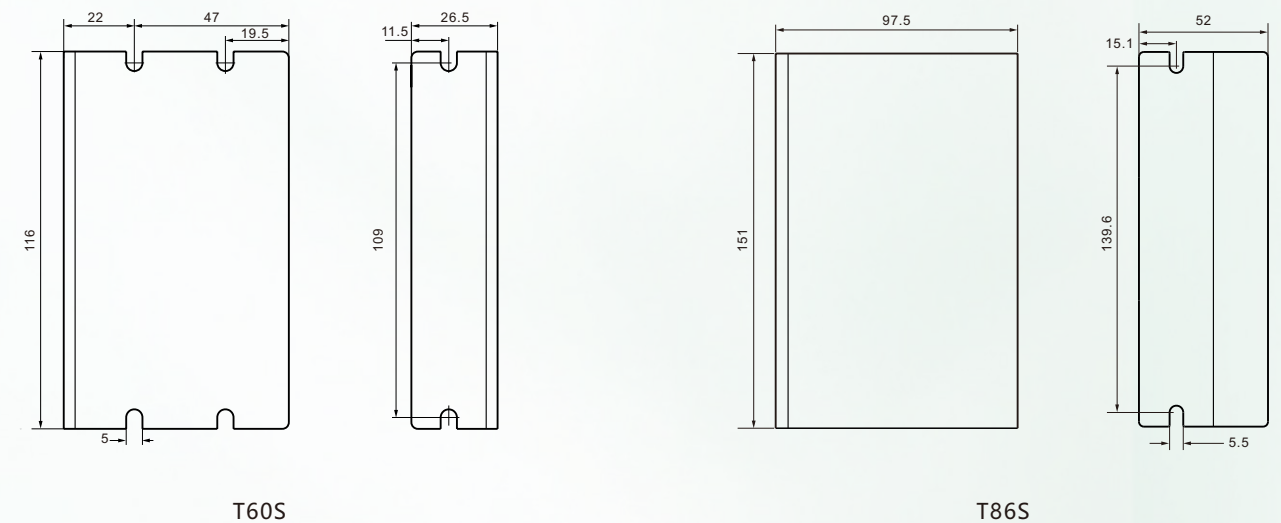

## Port Distribution

Debugging interface	
Identification	Instructions
3V3	When the drive is running normally, this 3V3 port should not provide external power. Otherwise, the operation performance and reliability of the motor will be affected
TX	RXD port to be connected to the debug cable
RX	TXD port to be connected to the debug cable
GND	GND port that needs to be connected to the debug cable



**Extended parameter dip switch**

SW1	Pulse/rev
SW2	Pulse/rev
SW3	Pulse/rev
SW4	Pulse/rev
SW5	Motor dir
SW6	Pulse filter
SW7	Pulse mode
SW8	Run mode

**LED indication**

Pulse signal  
Direction signal  
Enable signal  
Alarm output\*

**Encoder**

EB+	Encoder difference B+
EB-	Encoder difference B-
EA+	Encoder difference A+
EA-	Encoder difference A-
+5V	RS485 B
GND	—

**Power input interface**

T60S	T86S	Name
V+	AC	Positive pole
V-	AC	Negative pole

**Motor brake**

BRK+	Brake positive
BRK-	Brake negative

**Matching motor connection definition**

A+	A-	B+	B-
RED	BLU	GRN	BLK

**Note:**

- The polarity of the power supply of the T60S product cannot be reversed, otherwise the product will be damaged; T86S products can be connected to AC and DC.
- +5V is only for encoder use, not for other loads, otherwise it may damage the driver, maximum output current 100mA.
- Direct access to the driver without additional relay control, making the closed-loop control more reliable.

## Micro-stepping Setting

Pulse/rev		SW1	SW2	SW3	SW4
T60S	T86S				
3600	400	on	on	on	on
800	800	off	on	on	on
1600	1600	on	off	on	on
3200	3200	off	off	on	on
6400	6400	on	on	off	on
12800	12800	off	on	off	on
25600	25600	on	off	off	on
7200	51200	off	off	off	on
1000	1000	on	on	on	off
2000	2000	off	on	on	off
4000	4000	on	off	on	off
5000	5000	off	off	on	off
8000	8000	on	on	off	off
10000	10000	off	on	off	off
20000	20000	on	off	off	off
40000	40000	off	off	off	off

## Function Selection

Setting	Function	on	off
SW5	Motor dir	CW	CCW
SW6	Pulse filter	Enable	Disable
SW7	Pulse mode	CW/CCW	PUL/DIR
SW8	Run mode	Steeper	Servo

## Control Signal Interface

Identification	Name	Instructions
PUL24	24V pulse positive interface	1. Independent 5V and 24V pulse, direction control signal interface, The maximum voltage of the 24V interface is 28V, and the maximum voltage of the 5V interface is 7V.  2. EN+ and EN- are compatible with 5v to 24V  3. ALM+ and ALM -: Optocoupler isolated collector open circuit output.
PUL5	5V pulse positive interface	
PUL-	Pulse negative	
DIR24	24V direction positive interface	
DIR5	5V direction positive interface	
DIR-	Direction negative	
EN+	Enabling positive	
EN-	Enabling negative	
ALM+	Alarm output positive	
ALM-	Alarm output negative	

## LED Indication

LED status	Drive status	Fault handling
●	Steady green light	Drive not enabled
●●	Flashing green light	Drive working properly
●●●	1 green 1 red	Drive overcurrent
●●●●	1 green 2 red	Drive input power supply overvoltage
●●●●●	1 green 3 red	Drive internal voltage error
●●●●●●	1 green 4 red	Encoder out of tolerance alarm
●●●●●●●	1 green 5 red	Parameter check error
●●●●●●●●	1 green 6 red	Motor missing phase alarm
●●●●●●●●●	1 green 7 red	Check the terminal, confirm the extension cable connector

# Closed Loop Steppr Drive T Series

Rtelligent T series closed loop stepper driver, based on a brand-new DSP hardware platform, is designed using field-oriented (FOC) and weak magnetic control algorithms, offering performance that surpasses ordinary steppers in all aspects

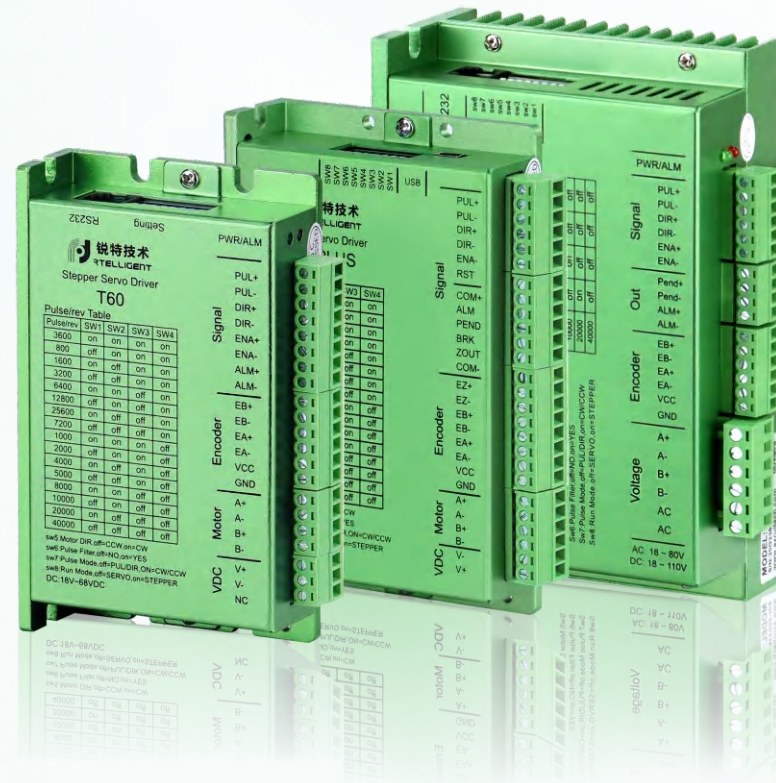

01  
No loss of step

02  
Fast response

03  
Large torque

04  
low heating

## Naming Rule





1 T: Closed Loop	3 Multi-function upgrade
2 Matching motor frame size	4 Non-standard code

\*Model naming rules are only used for model meaning analysis. For specific optional models, please refer to the details page.

## Technical Specifications

Model	Peak current A	Weight kg	Input voltage	Dimension mm	Number of micro-stepping	Pulse level	Matching motor
T42	3.0	0.2	18-68VDC	116×69×26.5	800-51200	3.3-24V	closed loop below 42mm
T60	6.0	0.2	18-68VDC	116×69×26.5	800-51200	3.3-24V	closed loop below 60mm
T60PLUS	6.0	0.3	18-48VDC	118×76×25	200-25600	5-24V	closed loop below 60mm
T86	7.0	0.6	18-80VAC	151×97×52	400-51200	3.3-24V	closed loop below 86mm

## Features

General-purpose T series	Functional PLUS series
 <ul style="list-style-type: none"> <li>• Matching motor frame below 86mm</li> <li>• PUL&amp;DIR or CW&amp;CCW</li> <li>• Auto-tuning match motor function</li> <li>• Smoothing filter function optional</li> <li>• Debugging software to modify and monitor drive parameters and status</li> </ul>	 <ul style="list-style-type: none"> <li>• Matching motor frame below 86mm</li> <li>• PUL&amp;DIR or CW&amp;CCW</li> <li>• Auto-tuning match motor function</li> <li>• Smoothing filter function optional</li> <li>• Debugging software to modify and monitor drive parameters and status</li> </ul>

# R-S Series Open Loop Pulse Control Stepper Drives

The R-S series is an upgraded version of the open-loop stepper drive launched by Rteelligent, and the product design idea is derived from the company's accumulation in the field of stepper drive over the years. With a new architecture and algorithm, the new generation of stepper driver effectively reduces the low-speed resonance amplitude of the motor, has a stronger anti-interference ability, while supporting sensorless stall detection, phase alarm and other functions, support a variety of pulse command forms, multiple dip setting functions.

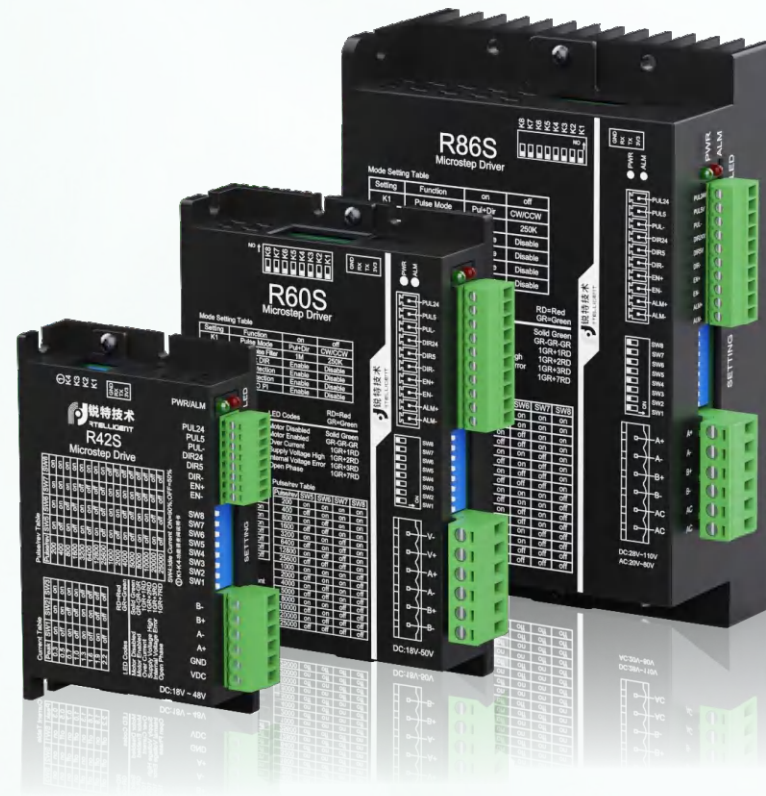

## Product Parameter

Model No.	R28S	R42S	R60S	R86S
Product photo				
Voltage range	12~24VDC	18~50VDC	18~50VDC	28~110VDC
AC input	Non support <sup>(1)</sup>	Non support <sup>(1)</sup>	Non support <sup>(1)</sup>	20~80VAC
Current range	0.3~1.0A	0.3~2.2A	1.4~5.6A	2.4~7.2A
Matching motor	Open loop motor below 28mm	Open loop motor below 42mm	Open loop motor below 60mm	Open loop motor below 86mm
Overcurrent self-recovery	Support <sup>(2)</sup>		Non support	
Debugging interface	Serial port TTL 3.3V			
Extended dip	SW8 Bit +k4 Bit		SW8 Bit + k8 Bit	
Alarm output	Non support <sup>(3)</sup>		1	
Pulse command voltage	5V 24V independent port			
Pulse command form	PUL+DIR/CW+CCW/QEP			
Pulse mode setting	PUL+DIR/CW+CCW Dip setting			
Pulse width setting	200K/600K Dip setting			
Direction inversion	Dip setting			
Stall detection	Dip setting			
Phase missing detection	Software setting <sup>(4)</sup>		Dip setting	
Instruction filter	Software setting <sup>(4)</sup>		Dip setting	

- 1) Drive that does not support AC input will be damaged if it is connected to an AC power supply
- 2) Built-in self-restoring fuse for maximum protection of motor and drive
- 3) The R28S and R42S do not have this hardware port
- 4) The parameter can be set through the debugging interface and debugging software

## Installation Dimension

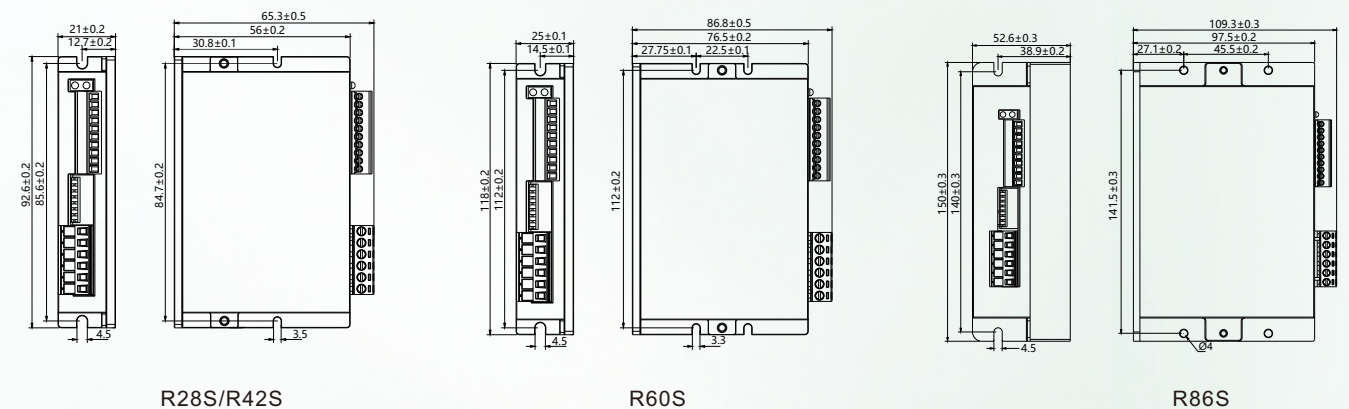

01 Auto tuning

02 Low speed vibration suppression

03 Sensorless stall detection

04 PUL+DIR/CW+CCW/QEP

05 Multiple dip setting

06 Three inputs and one output

07 Missing phase alarm

08 5V/ 24V pulse command independent

## Ports Distribution

Debugging interface

Identification	Instructions
3V3	When the drive is running normally, this 3V3 port should not provide external power. Otherwise, the operation performance and reliability of the motor will be affected
TX	RXD port to be connected to the debug cable
RX	TXD port to be connected to the debug cable
GND	GND port that needs to be connected to the debug cable



Extended parameter dip switch\*

K1	Pulse mode
K2	Pulse noise filter
K3	Invert DIR
K4	Stall detection
K5	OP detection
K6	Auto pi
K7	Smooth filter
K8	Smooth filter

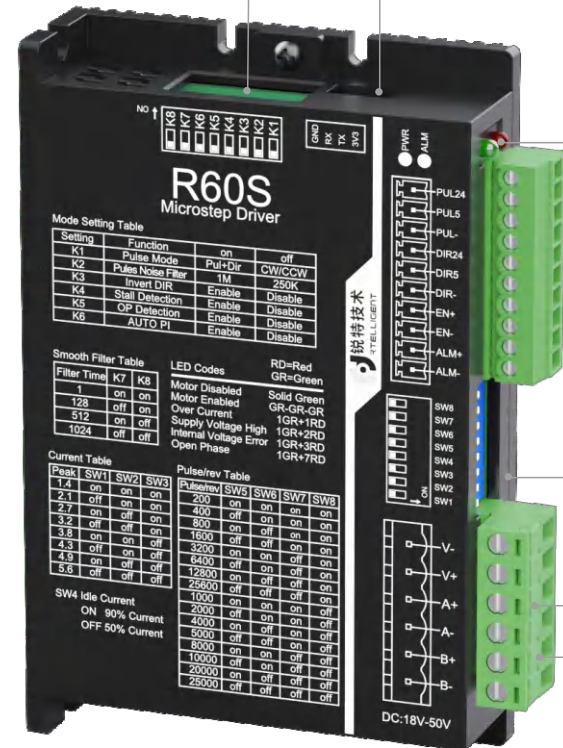

LED indication



Pulse signal  
Direction signal  
Enable signal  
Alarm output\*

SW1	Operating current
SW2	Operating current
SW3	Operating current
SW4	Idle current
SW5	Micro-stepping setting
SW6	Micro-stepping setting
SW7	Micro-stepping setting
SW8	Micro-stepping setting

Power input interface

Motor cable

Matching motor connection definition

A+	A-	B+	B-
RED	BLU	GRN	BLK



Notes:

- 1.R28S and R42S do not have alarm output interfaces.
2. The R28S and R42S do not have the K5-K8 function.
3. The R86S supports AC ranges from 20 to 80V

## Current Setting

Operating current (peak)/A				SW1	SW2	SW3
R28S	R42S	R60S	R86S			
0.3	0.3	1.4	2.4	on	on	on
0.4	0.5	2.1	3.1	off	on	on
0.5	0.7	2.7	3.7	on	off	on
0.6	1.0	3.2	4.4	off	off	on
0.7	1.3	3.8	5.1	on	on	off
0.8	1.6	4.3	5.8	off	on	off
0.9	1.9	4.9	6.5	on	off	off
1.0	2.2	5.6	7.2	off	off	off

## Semi-/full Current Selection

SW4	
off	50% current
on	90% current

## Micro-stepping Setting

Pulse/rev				SW5	SW6	SW7	SW8
R28S	R42S	R60S	R86S				
	200		400	on	on	on	on
	400		800	off	on	on	on
	800		1600	on	off	on	on
	1600		3200	off	off	on	on
	3200		6400	on	on	off	on
	6400		12800	off	on	off	on
	12800		25600	on	off	off	on
	25600		51200	off	off	off	on
	1000		1000	on	on	on	off
	2000		2000	off	on	on	off
	4000		4000	on	off	on	off
	5000		5000	off	off	on	off
	8000		8000	on	on	off	off
	10000		10000	off	on	off	off
	20000		20000	on	off	off	off
	25000		40000	off	off	off	off

## LED Indication

LED status	Drive status	Fault handling
●	Steady green light	Drive not enabled
●	Steady red light	Motor stalling
●●	Flashing green light	Drive works fine
●●	1 green 1 red	Drive overcurrent
●●●	1 green 2 red	Drive input power supply overvoltage
●●●●	1 green 3 red	Drive internal voltage error
●●●●●	1 green 7 red	Missing phase alarm
●●●●●●	1 green 8 red	Undervoltage alarm
		The EN port has a high level input
		Insufficient current, excessive load, driver failure
		-
		Check wiring, repair drive
		Check the input supply voltage
		Drive failure
		The motor wire is not connected properly
		The power supply voltage is too low

# R Series Stepper Drive

Rtelligent R series stepper driver, based on 32-bit DSP hardware platform, using micro-division technology and PID current control algorithm design, has a comprehensive performance beyond the ordinary analog stepper drive.



01 Adopt new micro-step algorithm

03 Reliable hardware platform

05 Multiple bus communication

02 Eliminate vibration

04 PID regulating parameter

06 S-type command smoothing

## Naming Rule



1 2 phase(omitted) 3: 3 phase 5: 5 phase	2 R: Open Loop
3 Matching motor frame size	4 Upgraded version X2: Two axis X3: Three axis
	5 Function code IO: Switch D: One-drive-two

\*Model naming rules are only used for model meaning analysis. For specific optional models, please refer to the details page.

## Technical Specifications

Model	Peak current A	Weight kg	Input voltage range	Dimension mm	Micro-stepping	Pulse level	Matching motor
R42	2	0.1	18-48VDC	92.6×56×21	200-25000	3.3-24V	Open loop below 42mm
R57	5.0	0.3	18-50VDC	118×76×33	400-25000	3.3-24V	Open loop below 57mm
R60	5.6	0.3	18-50VDC	118×76×33	200-25000	3.3-24V	Open loop below 60mm
R86	7.2	0.6	18-80VAC	151×97×52	400-40000	3.3-24V	Open loop below 86mm
R110PLUS	8.0	0.9	110-230VAC	178×109×68	400-25000	3.3-24V	Open loop below 110mm
R130	8.0	1.3	110-230VAC	203×147×78	400-60000	3.3-24V	Open loop below 130mm
3R60	8.0	0.3	18-50VDC	118×76×33	200-25000	3.3-24V	Open loop 3 phase below 60mm
3R110PLUS	7.2	0.9	110-230VAC	178×109×68	500-60000	3.3-24V	Open loop 3 phase below 110mm
3R130	8.0	1.3	110-230VAC	203×147×78	400-60000	3.3-24V	Open loop 3 phase below 130mm

## Function Description

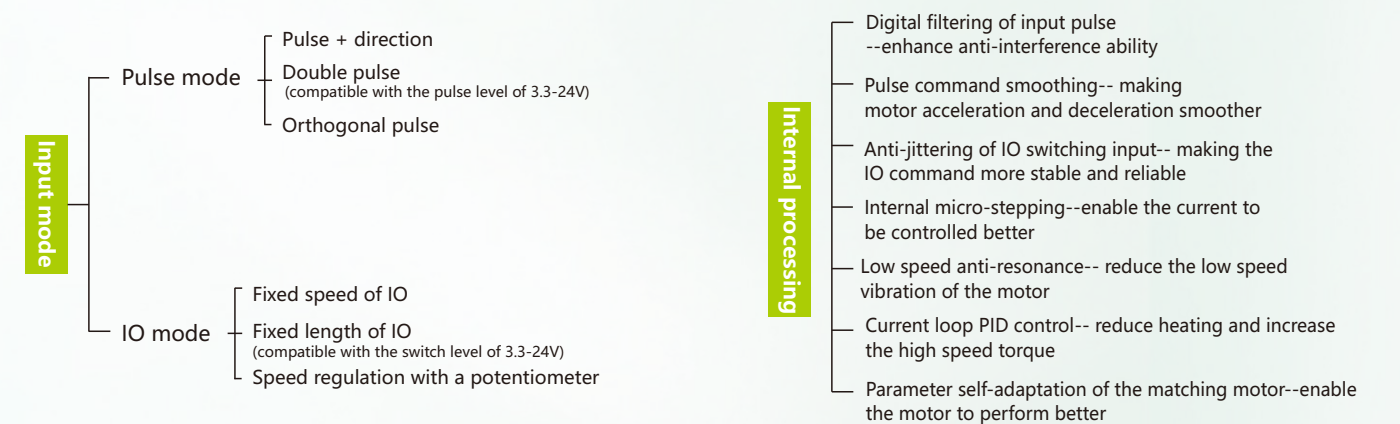

# Multi-axis Stepping System

Multi-axis automation equipment often demands space reduction and cost savings, giving rise to the Rtelligent multi-axis Series Drive. This product supports pulse control, switch control, and bus control, enabling independent or synchronized operation of multiple motors, making it suitable for various application scenarios. Compared with traditional drives, the multi-axis series can save 40%–60% of installation space, facilitating more flexible customer layouts.

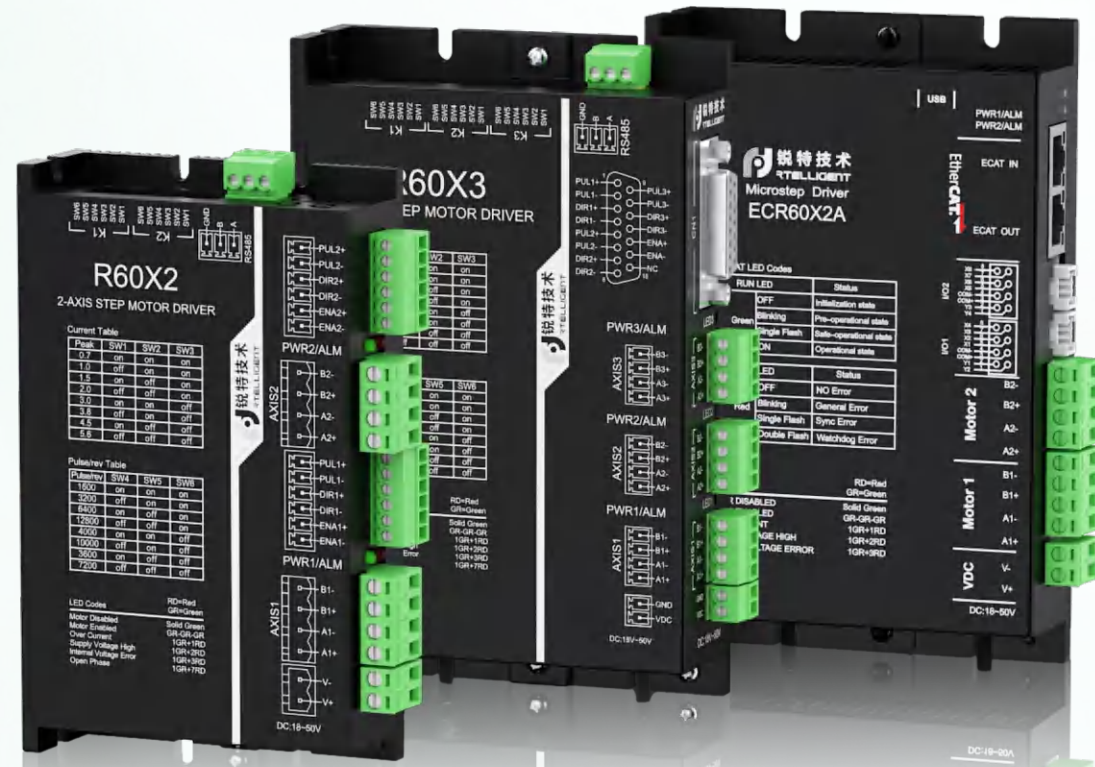

01

A variety of control methods optional

02

Save space and facilitate customer design

03

Save labor and shorten debugging time

04

Save cost, improve equipment competitiveness

## Step Extension Module based on EtherCAT protocol



Up to 16 modules can be expanded

### Technical Specifications

	Model	Peak current A	Weight kg	Input voltage	Dimension mm	Matching motor	
Multi-axis control series	Pulse	R42X2	2.2	0.2	18-50VDC	118×76×25	open loop below 42mm
		R60X2	5.6	0.4	18-48VDC	132×82×29	open loop below 60mm
		R60X3	5.6	0.5	18-48VDC	155×98×33	open loop below 60mm
	Field bus	ECR60X2A	6.0	0.5	18-80VDC	155×98×33	open loop below 60mm
		ECT60X2	6.0	0.5	18-80VDC	175×98×33	closed loop below 60mm
	RE-T60M	4.0	0.15	24-50VDC	110×86×22	open loop/ closed loop below 60mm	

# IO Control and Potentiometer Speed Regulating Stepper System

The Rteelligent IO Series switch-type stepper drive internally generates pulse trains with S-curve acceleration/ deceleration, requiring only simple switch signals to trigger motor start/stop.

## Product Features

- S-shaped acceleration and deceleration
- 8 current and 16 speed can be set
- Support open loop/closed loop
- Supports DIP switch between IO mode and pulse mode

## Technical Specifications

	Model	Peak current A	Input voltage	Dimension mm	Matching motor	
single-axis control series	switch type	R42IOS	2.2	18-48VDC	93X56X21	open loop below 42mm
		R60IOS	5.6	18-50VDC	118X77X25	open loop below 60mm
		R86IOS	7.2	28-110VDC	150X98X53	open loop below 86mm
	potentiometer speed regulation type	R110PLUS-IO	8.0	110-230VAC	178X97X52	open loop below 110mm
		R130-IO	8.0	110-230VAC	203X147X78	open loop below 130mm
		T60IOS	6.0	18-50VDC	116X69X27	closed loop below 60mm
		T86IOS	8.0	28-110VDC	151X98X52	closed loop below 86mm
potentiometer speed regulation type	R42IRS	2.2	18-48VDC	93X56X21	open loop below 42mm	
	R60IRS	5.6	18-50VDC	118X77X25	open loop below 60mm	
	R86IRS	7.2	28-110VDC	150X98X53	open loop below 86mm	

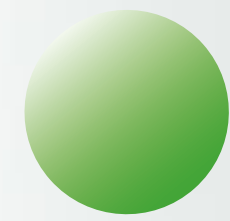

Conveying equipment



Inspection conveyor



PCB feeding machine

# 5 Phase Stepper System

The Rtelligent Five-Phase Stepper Drive is compatible with Japanese-style "new pentagon" connection motors, delivering exceptional performance. Built on a 32-bit DSP hardware platform, the drive incorporates micro-stepping technology and a PID current control algorithm, achieving all-around superior performance compared to conventional stepper drives.



01  
High precision

02  
Small torque ripple

03  
Low vibration

04  
High repeat positioning accuracy

05  
High reliability

06  
Stable hardware platform

## Features

— Two-phase — Five-phase

### High precision

The step angle of the five-phase stepper motor is 0.72°, which has higher step angle accuracy than the two-phase/three-phase stepper motor.

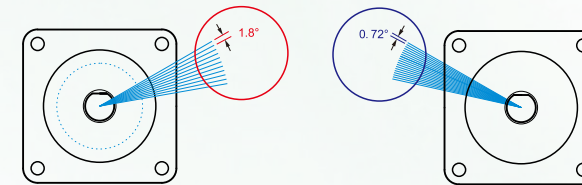

### Low vibration

The stator of the five-phase stepper motor contains five pairs of windings. The decoupling algorithm of the drive makes the winding current of the five-phase stepper motor in a more reliable equilibrium state. The motor runs smoothly with little vibration.

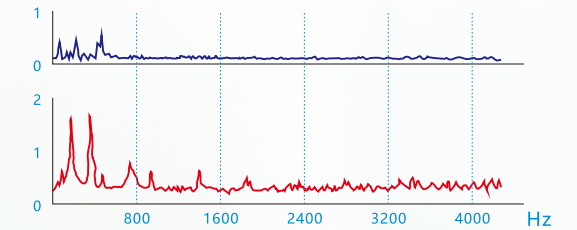

### Small torque ripple

Because of its unique structure and current control algorithm, the five-phase stepper system has a smaller torque ripple in the same electrical cycle of the stepper motors. Therefore, the five-phase system has unique advantages in speed stability.

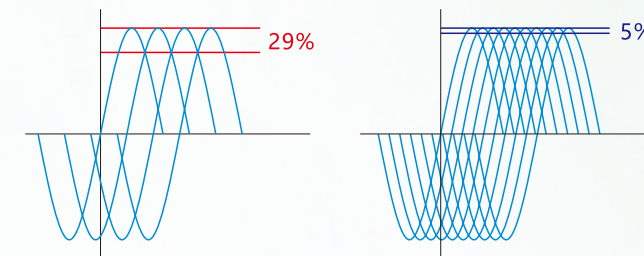

### High repeat positioning accuracy

The step angle error of stepper motor depends on the manufacturing process, generally 3%-5% of the step angle. In each interval of 50 pairs of rotor cogging, the five-phase motor corresponds to 10 stable positions, which has better repeat positioning accuracy.

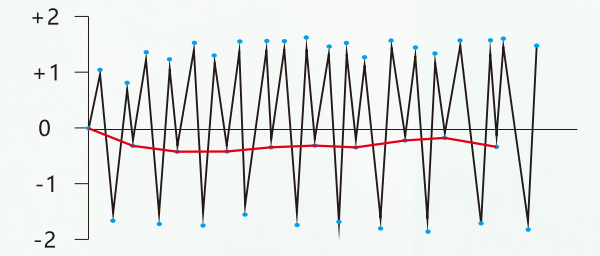

## Technical Spec.

Model	5R42	5R60	5ECR42
Product picture			
Control mode	Pulse & direction, double pulse		EtherCAT
Input voltage	24-36VDC	18-50VDC	18-36VDC
Output current	0.3-2.2A	0.5-3.5A	0.1-2.5A
dimension	93X56X21	118X76X25	134X82X29
Digital input	-		4 common-anode 24V inputs
Digital output	1 photoelectric isolation output, default alarm output		2 optical isolation outputs
Debugging port	Micro USB		Mini USB
Matching motor	open loop below 42mm	open loop below 60mm	open loop below 42mm

\*Please refer to P60 for the matching motor.

# Stepper Motor Series

1.8°  
2 phase

1.2°  
3 phase

0.72°  
5 phase

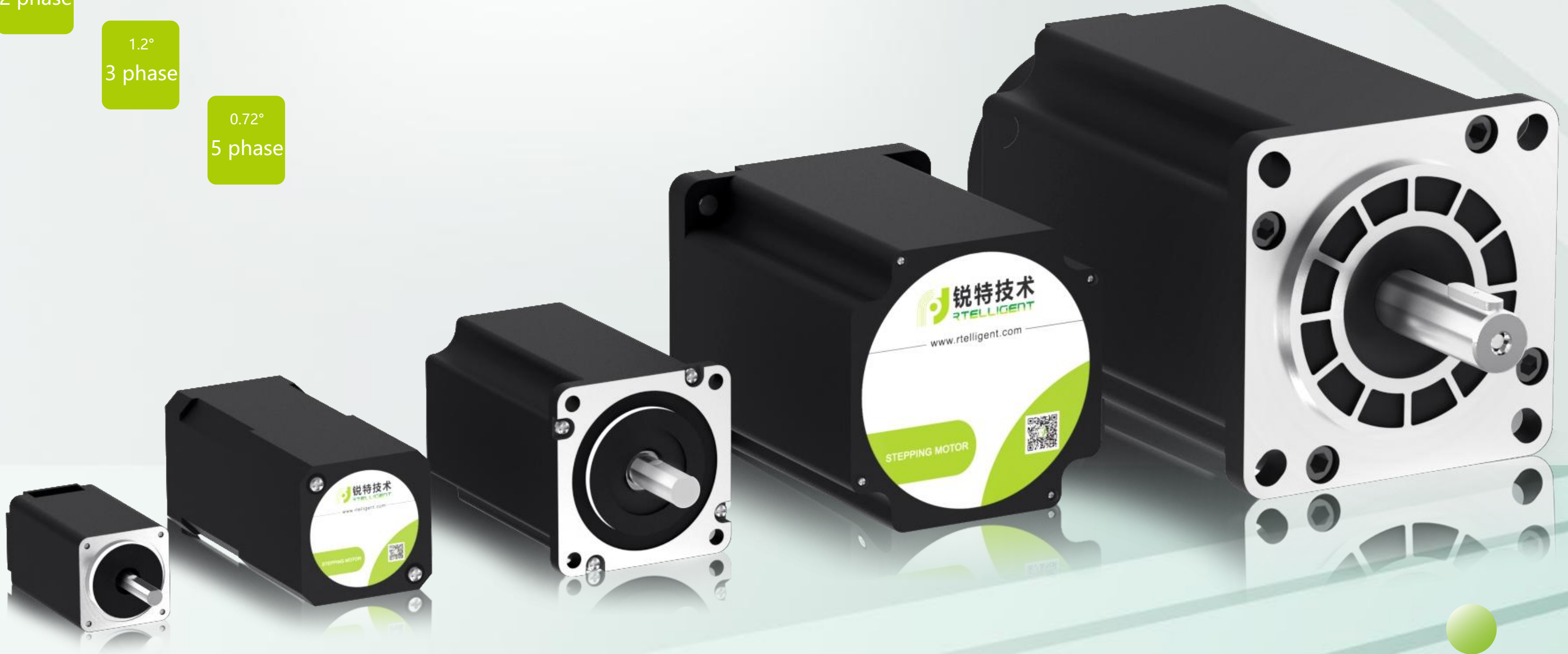

# Closed Loop Stepper Motor Series

Rtelligent new closed loop stepper motor AM series is based on the Cz optimized magnetic circuit design and the latest compact M-type mold. The motor body adopts high magnetic density stator and rotor materials, featuring high energy efficiency.

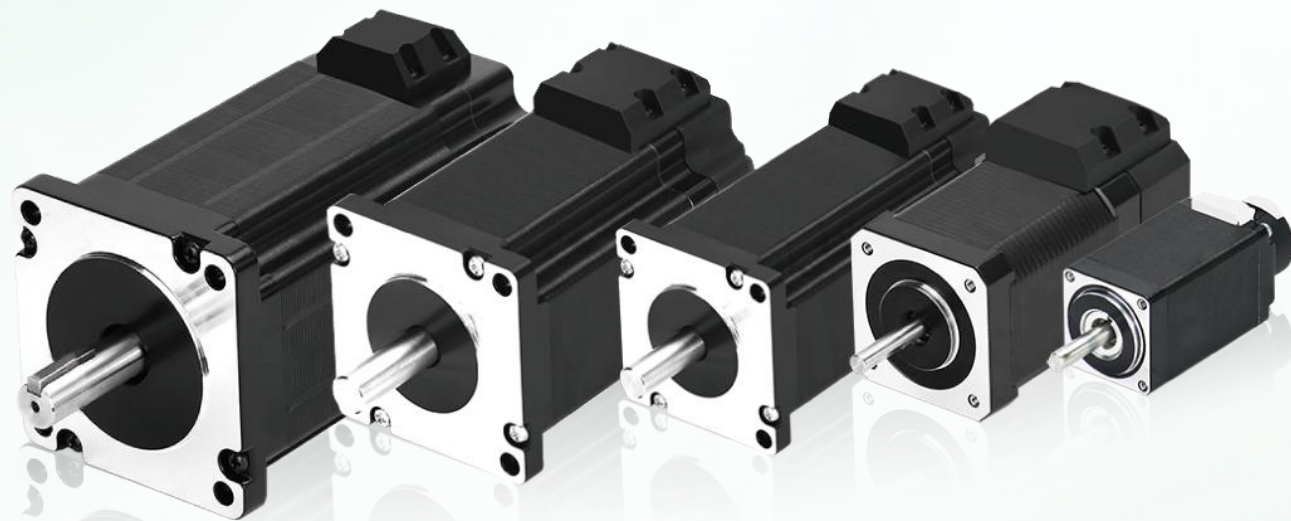

## Naming Rule

57 A M 23 E D Z - □  
 1 2 3 4 5 6 7 8

1 Base size	2 Step angle type code A: 1.8 degrees B: 1.2 degrees C: 0.72 degrees	3 Motor series code M: M series
4 Motor torque 0.6: 0.6N·m 30: 3.0N·m 120: 12.0N·m	5 Encoder type E: 1000 line photoelectric encoder	6 Type of plug C: Encoder AMP6 plug outlet D: Encoder DB9 plug outlet X: Encoder DB9/Motor AMP4 plug T: Encoder AMP6/Motor AMP4 plug H: Encoder AMP9/Motor AMP4 plug (high voltage)
7 Supplementary code Z: Encoder with Z signal	8 Non-standard code Z2: with brake	

\*Model naming rules are only used for model meaning analysis. For specific optional models, please refer to the details page

## 2-phase Stepper Motor 20/28mm Series Technical Specifications

Model	Step angle (°)	Holding torque(N.m)	Rated current(A)	Resistance/Phase(Ohm)	Inductance/Phase(mH)	Rotor inertia (g.cm <sup>2</sup> )	Shaft diameter(mm)	Shaft length (mm)	Length (mm)	Weight (kg)
20AM003EC	1.8	0.03	0.6	5.7	2.6	3	4	20	46.0	0.09
28AM006EC	1.8	0.06	1.2	1.4	1.0	90	5	20	44.7	0.13
28AM013EC	1.8	0.13	1.2	2.2	2.3	180	5	20	63.6	0.22

\*NEMA 8 (20mm), NEMA 11 (28mm)

### 20 Series Dimension (mm)

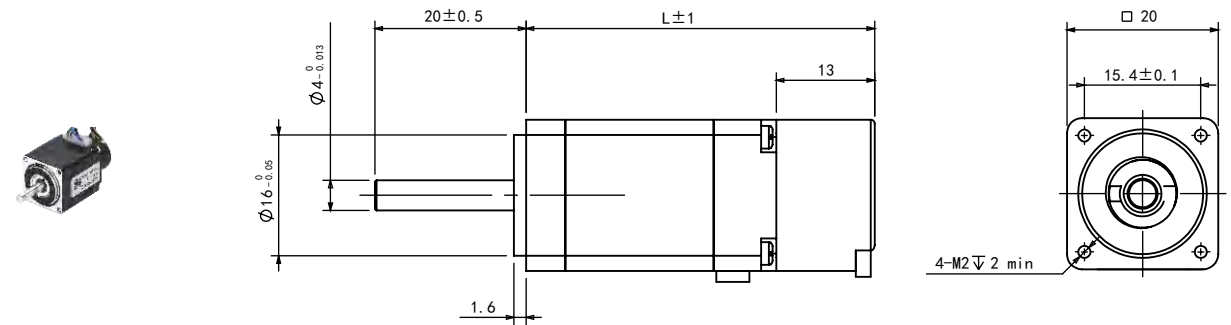

### 28 Series Dimension (mm)

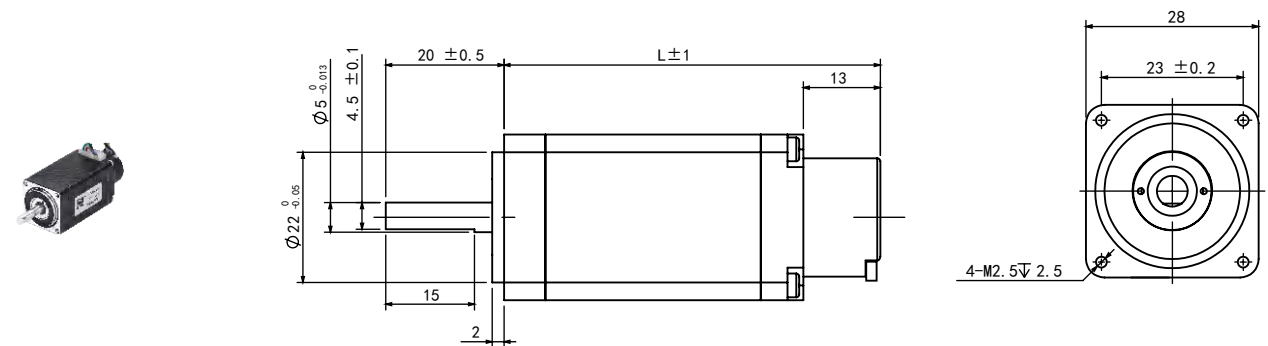

## Torque-frequency Curve

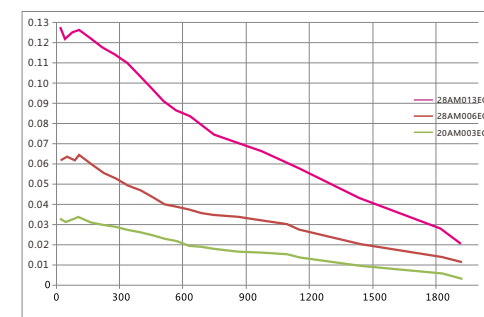

Drive: T42  
Voltage: 24VDC  
Current: Rated  
Micro-stepping: 1600

## Wiring Definition

A+	A-	B+	B-
Red	Blue	Green	Black

EB+	EB-	EA+	EA-	5V	GND
Yellow	Green	Black	Brown	Red	White

## 2-phase Stepper Motor 42mm Series Technical Specifications

Model	Step angle (°)	Holding torque(N.m)	Rated current(A)	Resistance/Phase(Ohm)	Inductance/Phase(mH)	Rotor inertia (g.cm <sup>2</sup> )	Shaft diameter(mm)	Shaft length (mm)	Length (mm)	Weight (kg)
42A03EC	1.8	0.3	2.0	1.6	1.9	77	8	21	69	0.5
42A08EC	1.8	0.8	2.8	2.7	2.3	115	8	21	85	0.6
42AM06ED	1.8	0.6	2.0	1.1	1.5	82	5	24	67	0.4
42AM08ED	1.8	0.8	2.0	1.9	5.0	114	5	24	79	0.6

\*NEMA 17 (42mm)

### 42A Series Dimension (mm)

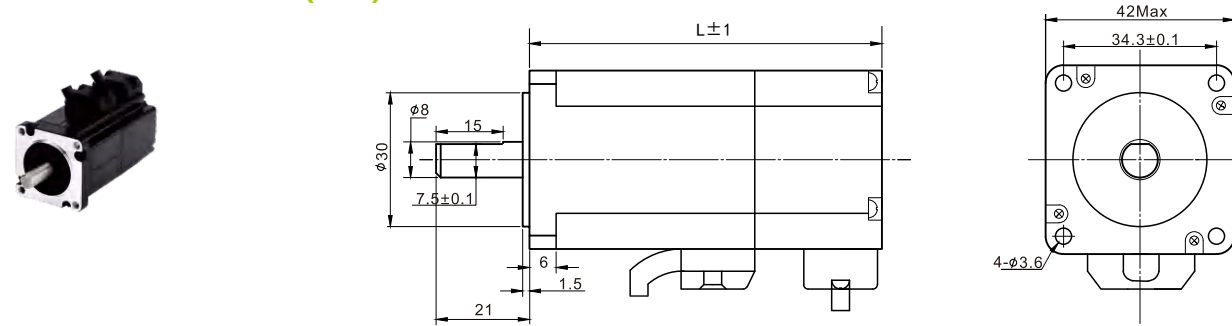

### Torque-frequency Curve

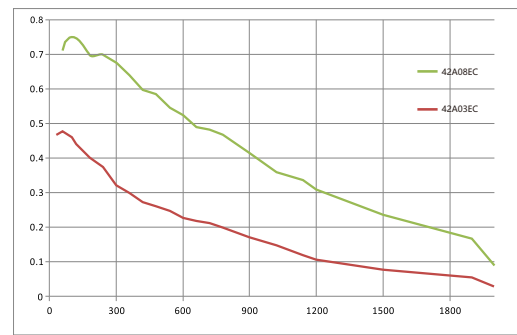

Drive: T42 Voltage: 24VDC Current: Rated Micro-stepping: 1600

### Wiring Definition

A+	A-	B+	B-
Red	Black	Yellow	Blue

EB+	EB-	EA+	EA-	5V	GND
Green	Yellow	Brown	White	Red	Blue

### 42A Series Dimension (mm)

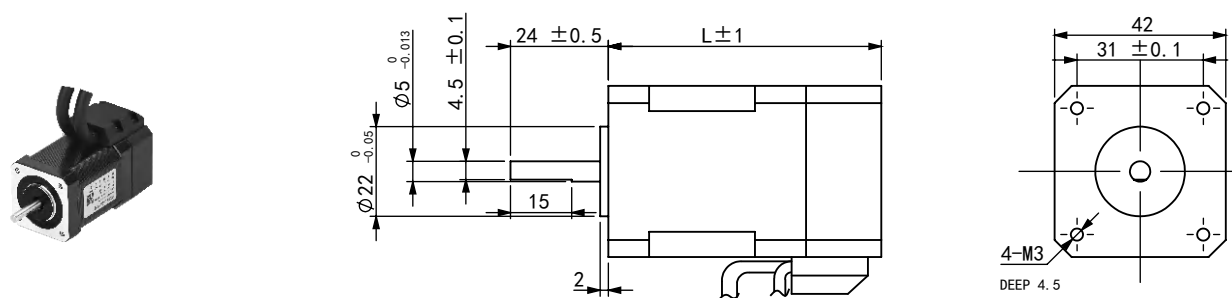

### Torque-frequency Curve

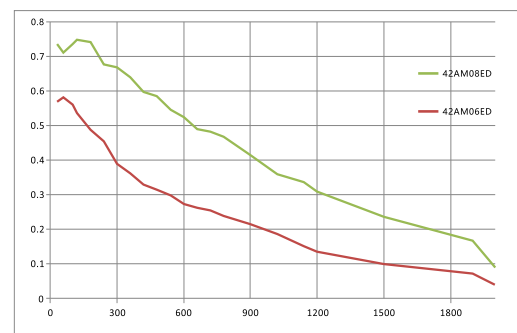

Drive: T42 Voltage: 24VDC Current: Rated Micro-stepping: 1600

### Wiring Definition

A+	A-	B+	B-
Red	Blue	Green	Black

EB+	EB-	EA+	EA-	5V	GND
Green	Yellow	Brown	White	Red	Blue

## 2-phase Stepper Motor 57mm Series Technical Specifications

Model	Step angle (°)	Holding torque(N.m)	Rated current(A)	Resistance/Phase(Ohm)	Inductance/Phase(mH)	Rotor inertia (g.cm <sup>2</sup> )	Shaft diameter(mm)	Shaft length (mm)	Length (mm)	Weight (kg)
57AM13ED	1.8	1.3	4.0	0.4	1.6	260	8	22	77	0.8
57AM23ED	1.8	2.3	5.0	0.6	2.4	460	8	22	98	1.2
57AM26ED	1.8	2.6	5.0	0.5	2.1	520	8	22	106	1.4
57AM30ED	1.8	3.0	5.0	0.8	3.7	720	8	22	124	1.5
D57AM30ED	1.8	3.0	5.0	0.5	2.2	690	8	22	107	1.5

\*NEMA 23 (57mm)

### 57 Series Dimension (mm)

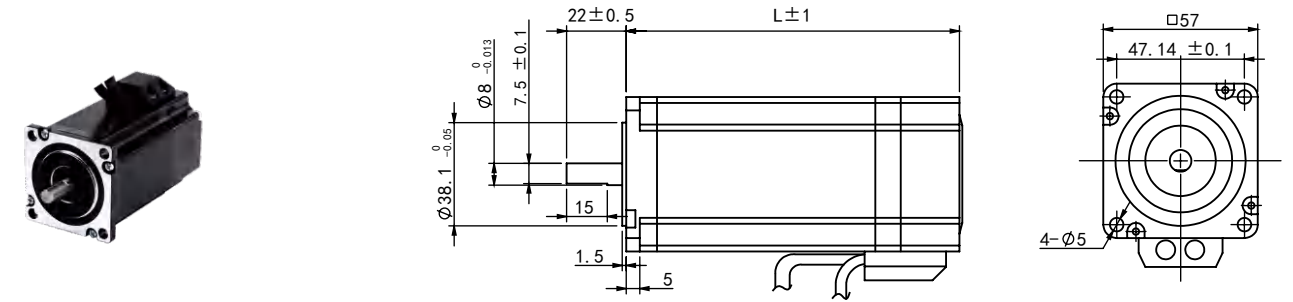

### D57 Series Dimension (mm)

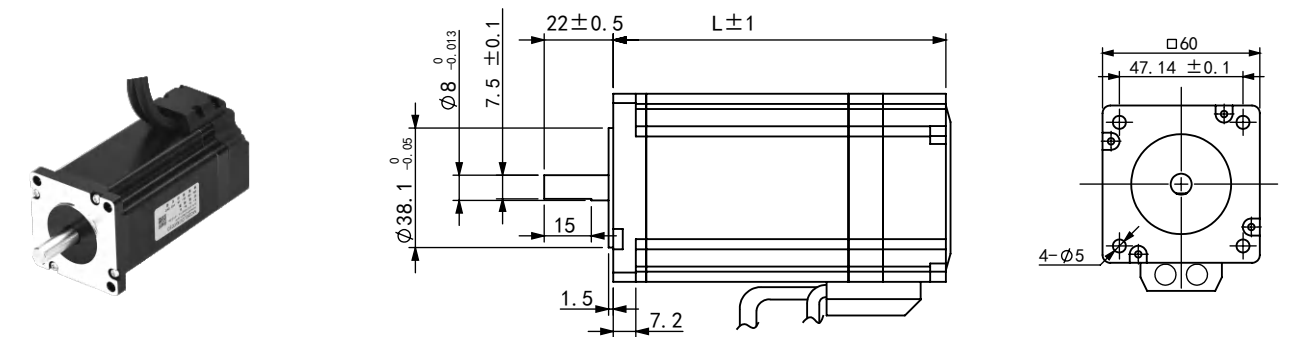

### Torque-frequency Curve

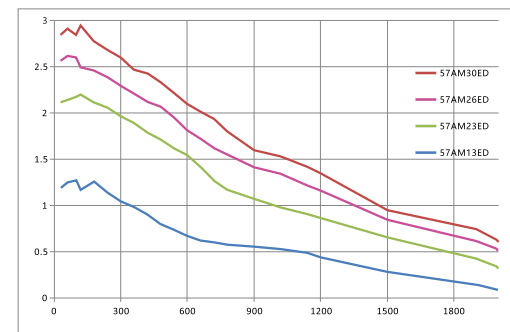

Drive: T60 Voltage: 36VDC Current: Rated Micro-stepping: 1600

### Wiring Definition

A+	A-	B+	B-
Red	Blue	Green	Black

EB+	EB-	EA+	EA-	5V	GND
Green	Yellow	Brown	White	Red	Blue

## 2-phase Stepper Motor 60mm Series Technical Specifications

Model	Step angle (°)	Holding torque(N.m)	Rated current(A)	Resistance/Phase(Ohm)	Inductance/Phase(mH)	Rotor inertia (g.cm <sup>2</sup> )	Shaft diameter(mm)	Shaft length (mm)	Length (mm)	Weight (kg)
60AM22ED	1.8	2.2	5.0	0.4	1.3	330	8	22	79	1.1
60AM30ED	1.8	3.0	5.0	0.5	2.2	690	8	22	107	1.5
60AM40ED	1.8	4.0	5.0	0.9	3.5	880	10	30	123	2.1

\*NEMA 24 (60mm)

### 60 Series Dimension (mm)

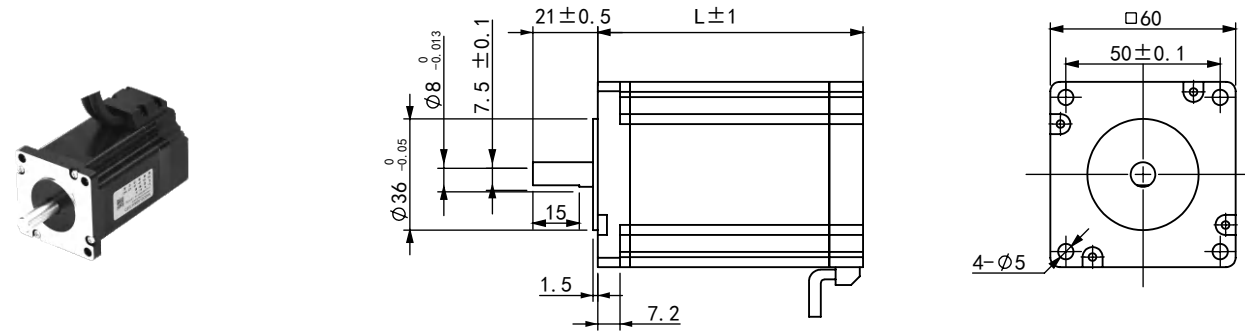

### 60AM40ED Dimension (mm)

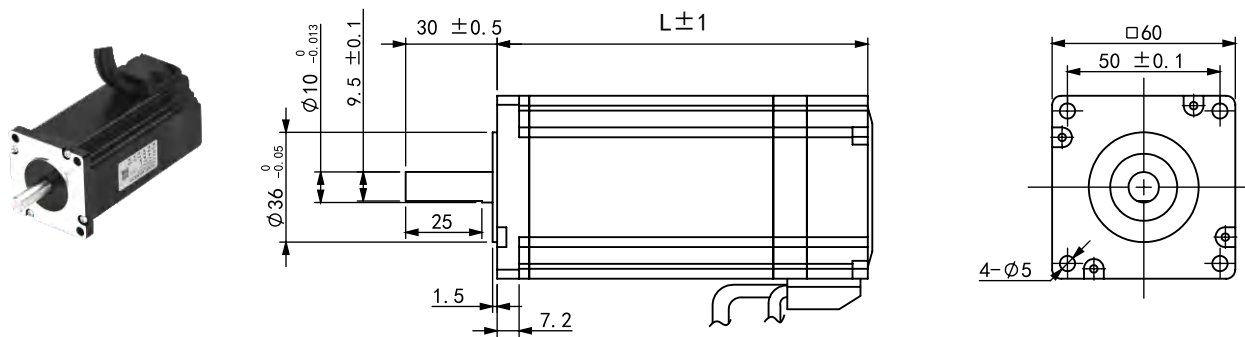

### Torque-frequency Curve

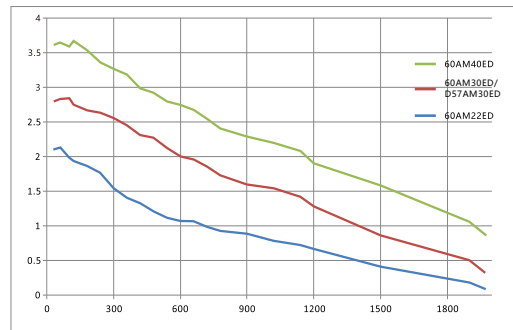

Drive: T60  
Voltage: 48VDC  
Current: Rated  
Micro-stepping: 1600

### Wiring Definition

A+	A-	B+	B-
Red	Blue	Green	Black

EB+	EB-	EA+	EA-	5V	GND
Green	Yellow	Brown	White	Red	Blue

## 2-phase Stepper Motor 86mm Series Technical Specifications

Model	Step angle (°)	Holding torque(N.m)	Rated current(A)	Resistance/Phase(Ohm)	Inductance/Phase(mH)	Rotor inertia (g.cm <sup>2</sup> )	Shaft diameter(mm)	Shaft length (mm)	Length (mm)	Weight (kg)
86AM45ED	1.8	4.5	6.0	0.4	2.8	1400	14	40	105	2.5
86AM65ED	1.8	6.5	6.0	0.5	4.2	2300	14	40	127	3.3
86AM85ED	1.8	8.5	6.0	0.5	5.5	2800	14	40	140	3.9
86AM100ED	1.8	10	6.0	0.8	5.3	3400	14	40	157	4.3
86AM120ED	1.8	12	6.0	0.7	8.3	4000	14	40	182	5.3

\*NEMA 34 (86mm)

### 60 Series Dimension (mm)

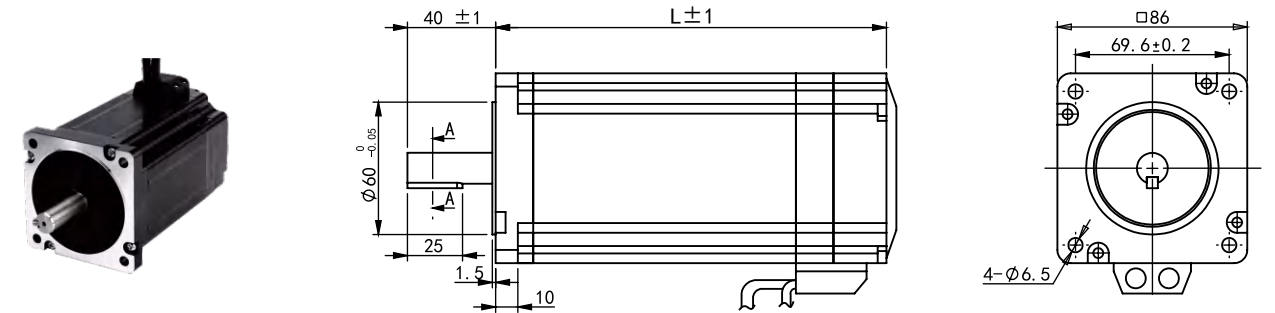

### Torque-frequency Curve

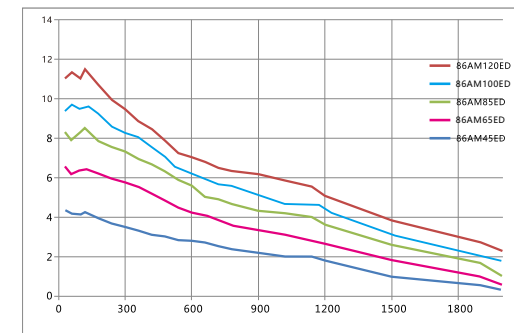

Drive: T86  
Voltage: 60VAC  
Current: Rated  
Micro-stepping: 1600

### Wiring Definition

A+	A-	B+	B-
Red	Blue	Green	Black

EB+	EB-	EA+	EA-	5V	GND
Green	Yellow	Brown	White	Red	Blue

# Open Loop Stepper Motor

Rtelligent open loop stepper motor, based on the Cz optimized magnetic circuit design and using high magnetic density stator and rotor materials, has a relatively high energy efficiency.

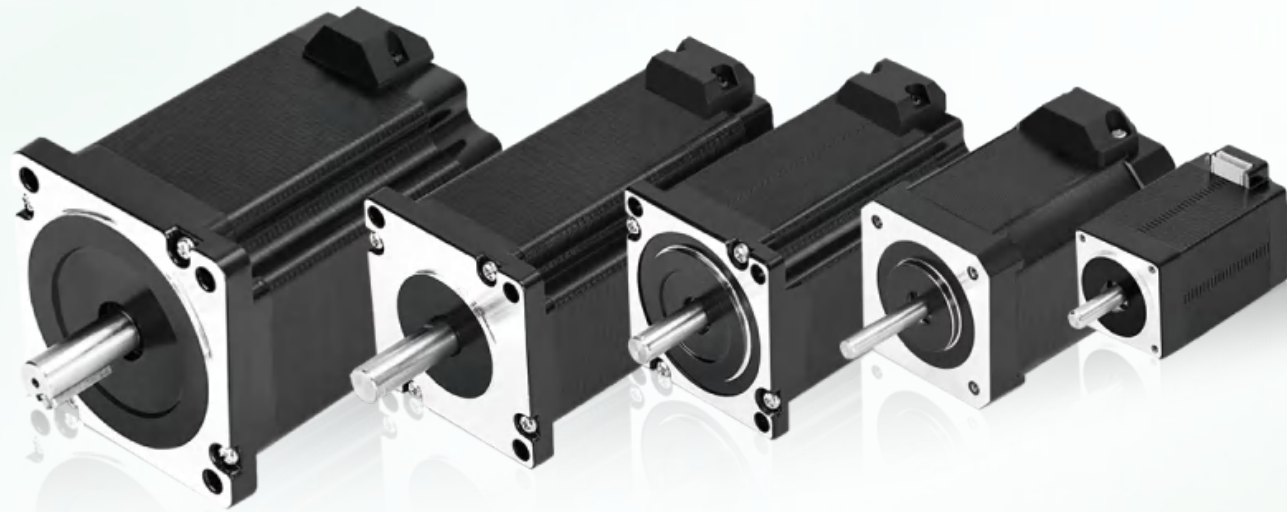

## Naming Rule

57 A M 23 - □  
 ① ② ③ ④ ⑤

<b>①</b> Base size	<b>②</b> Step angle type code A: 1.8 degrees B: 1.2 degrees C: 0.72 degrees	<b>③</b> Motor series code M: M series
<b>④</b> Motor torque 0.6: 0.6Nm 30: 3.0Nm 120: 12.0Nm		<b>⑤</b> Non-standard code D: Double shaft Z2: With brake

\*Model naming rules are only used for model meaning analysis. For specific optional models, please refer to the details page.

## 2-Phase Stepper Motor 20/28mm Series Technical Specifications

Model	Step angle (°)	Holding torque(N.m)	Rated current(A)	Resistance/Phase(Ohm)	Inductance/Phase(mH)	Rotor inertia (g.cm <sup>2</sup> )	Shaft diameter(mm)	Shaft length (mm)	Length (mm)	Weight (kg)
20AM003	1.8	0.03	0.6	5.7	2.6	3	4	10	33	0.07
20AM005	1.8	0.05	0.6	7.0	3.4	38	4	10	45	0.10
28AM006	1.8	0.06	1.2	1.4	1.0	90	5	20	32	0.11
28AM01	1.8	0.10	1.2	1.8	1.6	130	5	20	41	0.13
28AM013	1.8	0.13	1.2	2.2	2.3	180	5	20	51	0.18

\*NEMA 8 (20mm), NEMA 11 (28mm)

### 20AM Series Dimension (mm)

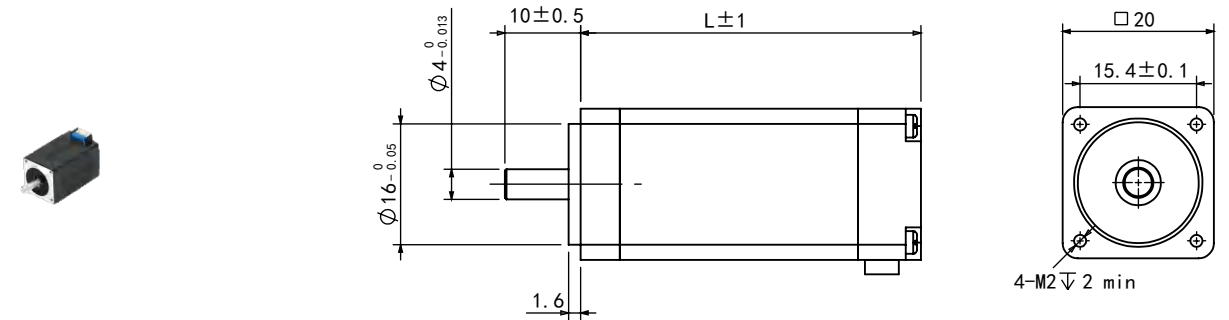

### 28AM Series Dimension (mm)

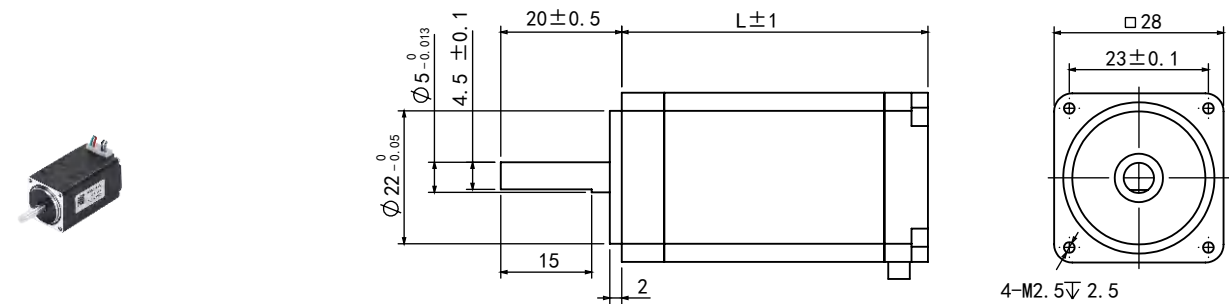

### Torque-frequency Curve

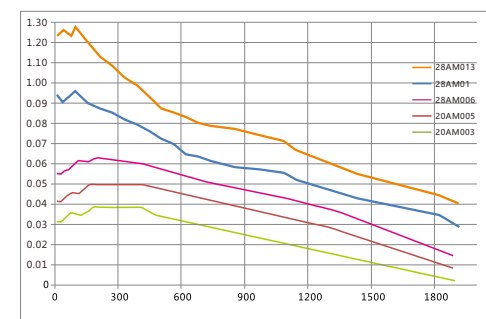

Drive: R42 Voltage: 24VDC Current: Rated Micro-stepping: 1600

### Wiring

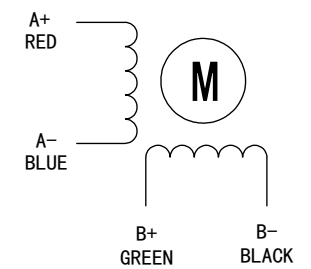

### 2-Phase Stepper Motor 35/39mm Series Technical Specifications

Model	Step angle (°)	Holding torque(N.m)	Rated current(A)	Resistance/Phase(Ohm)	Inductance/Phase(mH)	Rotor inertia (g.cm <sup>2</sup> )	Shaft diameter(mm)	Shaft length (mm)	Length (mm)	Weight (kg)
35A02	1.8	0.2	1.0	3.8	5.3	22	5	20	34	0.18
39A02	1.8	0.2	1.0	4.1	7.1	30	5	20	36	0.28

\*NEMA 14 (35mm), NEMA 16 (39mm)

#### 35A Series Dimension (mm)

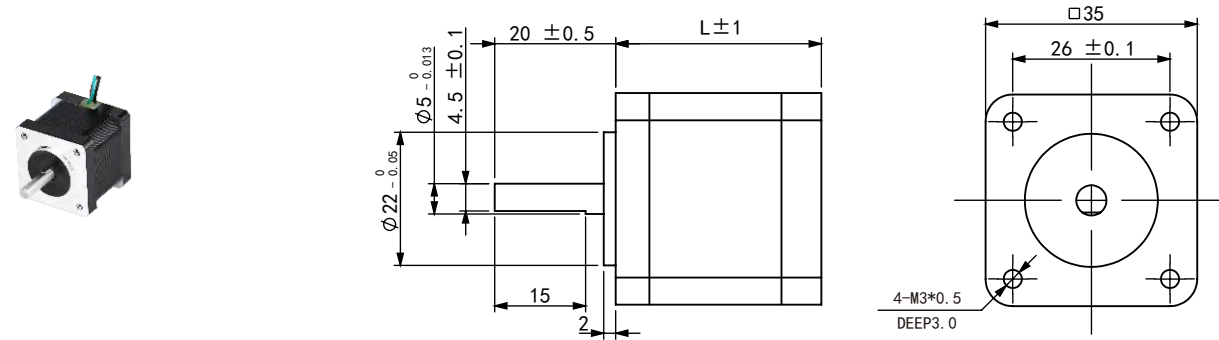

#### 39A Series Dimension (mm)

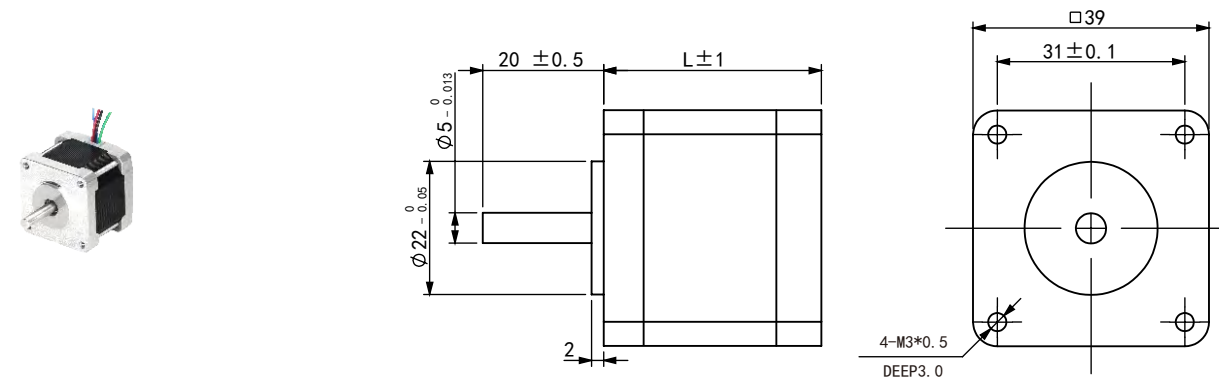

#### Torque-frequency Curve

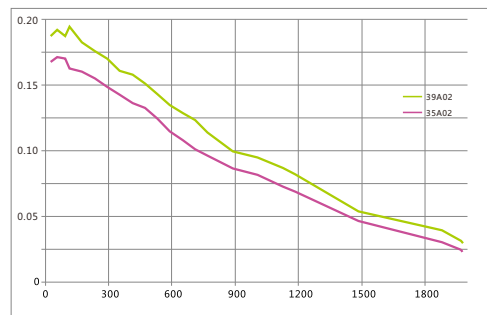

Drive: R42  
Voltage: 24VDC  
Current: Rated  
Micro-stepping: 1600

#### Wiring

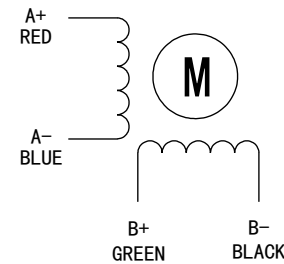

### 2-Phase Stepper Motor 42mm Series Technical Specifications

Model	Step angle (°)	Holding torque(N.m)	Rated current(A)	Resistance/Phase(Ohm)	Inductance/Phase(mH)	Rotor inertia (g.cm <sup>2</sup> )	Shaft diameter(mm)	Shaft length (mm)	Length (mm)	Weight (kg)
42AM02	1.8	0.2	1.5	1.3	1.9	41	5	24	34	0.23
42AM04	1.8	0.4	1.5	2.6	5.1	57	5	24	40	0.29
42AM06	1.8	0.6	2.0	1.8	3.8	82	5	24	47	0.37
42AM08	1.8	0.8	2.0	1.9	5.0	114	5	24	60	0.48

\*NEMA 17 (42mm)

#### 42AM Series Dimension (mm)

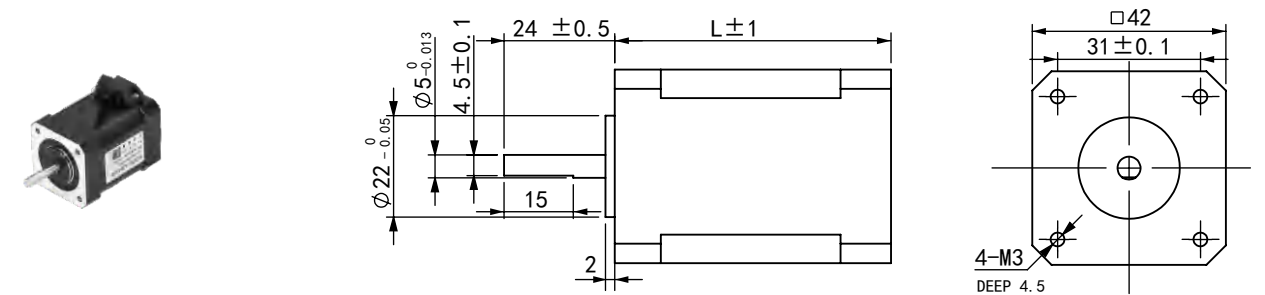

#### Torque-frequency Curve

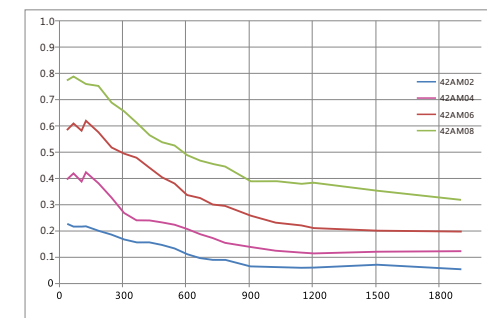

Drive: R42  
Voltage: 24VDC  
Current: Rated  
Micro-stepping: 1600

#### Wiring

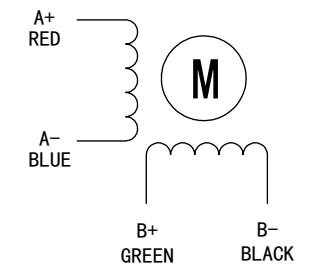

### 2-Phase Stepper Motor 42mm Series Technical Specifications

Model	Step angle (°)	Holding torque(N.m)	Rated current(A)	Resistance/Phase(Ohm)	Inductance/Phase(mH)	Rotor inertia (g.cm <sup>2</sup> )	Shaft diameter(mm)	Shaft length (mm)	Length (mm)	Weight (kg)
42A01	1.8	0.15	1.0	1.3	1.9	41	5	24	34	0.23
42A02	1.8	0.2	1.2	2.6	5.1	57	5	24	40	0.29
42A03	1.8	0.3	2.0	1.8	3.8	82	5	24	47	0.37
42A08	1.8	0.8	2.0	1.9	5.0	114	5	24	60	0.48

\*NEMA 17 (42mm)

#### 42A Series Dimension (mm)

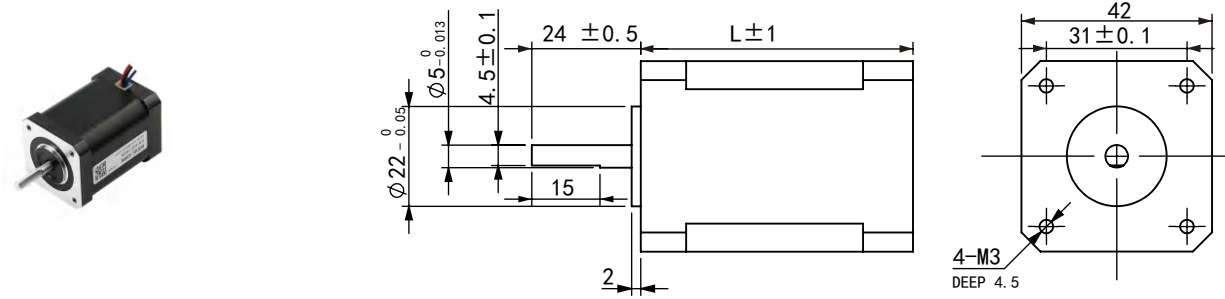

#### Torque-frequency Curve

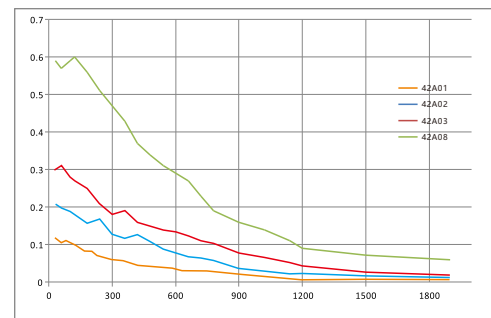

Drive: R42  
Voltage: 24VDC  
Current: Rated  
Micro-stepping: 1600

#### Wiring

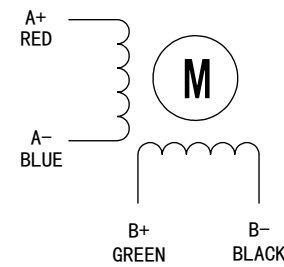

### 2-Phase Stepper Motor 57mm Series Technical Specifications

Model	Step angle (°)	Holding torque(N.m)	Rated current(A)	Resistance/Phase(Ohm)	Inductance/Phase(mH)	Rotor inertia (g.cm <sup>2</sup> )	Shaft diameter(mm)	Shaft length (mm)	Length (mm)	Weight (kg)
57AM13	1.8	1.3	3.0	0.42	1.5	260	8	21	55	0.67
57AM23	1.8	2.3	5.0	0.64	2.7	460	8	21	76	1.03
57AM24	1.8	2.4	5.6	0.41	2.0	460	8	21	80	1.11
57AM26	1.8	2.6	5.0	0.47	2.1	520	8	21	84	1.20
57AM30	1.8	3.0	5.0	0.82	3.7	720	8	21	102	1.48
D57AM30	1.8	3.0	5.0	0.50	2.2	690	8	21	86	1.39

\*NEMA 23 (57mm)

#### 57AM Series Dimension (mm)

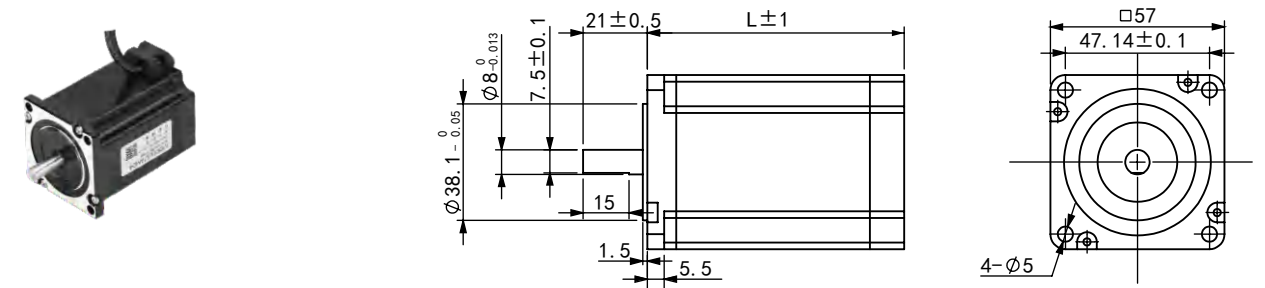

#### D57AM Series Dimension (mm)

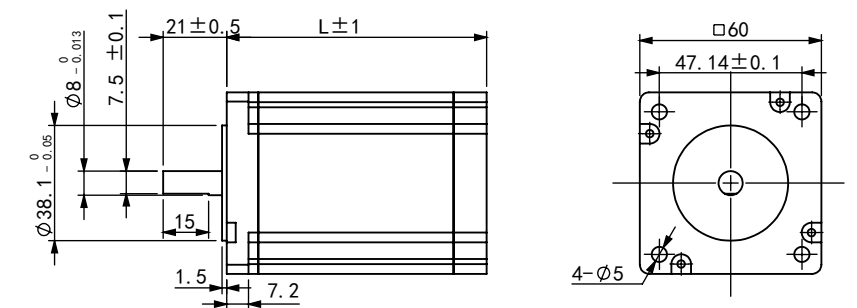

#### Torque-frequency Curve

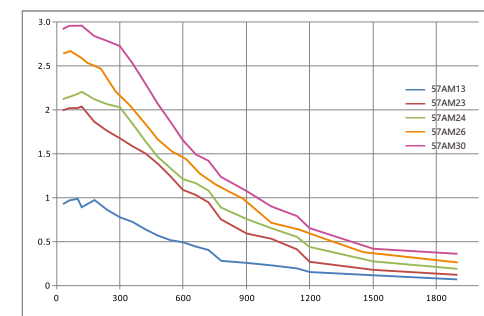

Drive: R60  
Voltage: 36VDC  
Current: Rated  
Micro-stepping: 1600

#### Wiring

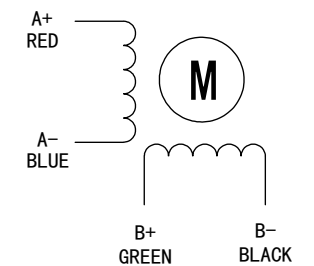

### 2-Phase Stepper Motor 57mm Series Technical Specifications

Model	Step angle (°)	Holding torque(N.m)	Rated current(A)	Resistance/Phase(Ohm)	Inductance/Phase(mH)	Rotor inertia (g.cm <sup>2</sup> )	Shaft diameter(mm)	Shaft length (mm)	Length (mm)	Weight (kg)
57A09	1.8	0.9	2.8	0.42	1.53	260	6.35	21	55	0.67
57A1	1.8	1.3	2.8	0.64	2.65	460	6.35	21	76	1.03
57A2	1.8	2.2	4.0	0.41	2.00	460	8.00	21	80	1.11
57A3	1.8	3.0	5.0	0.82	3.73	720	8.00	21	102	1.48

\*NEMA 23 (57mm)

#### 57A09/57A1 Dimension (mm)

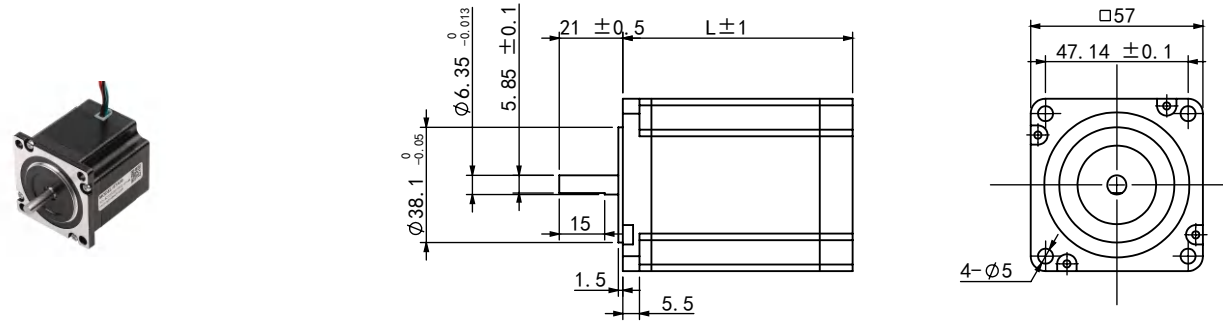

#### 57A2/57A3 Dimension (mm)

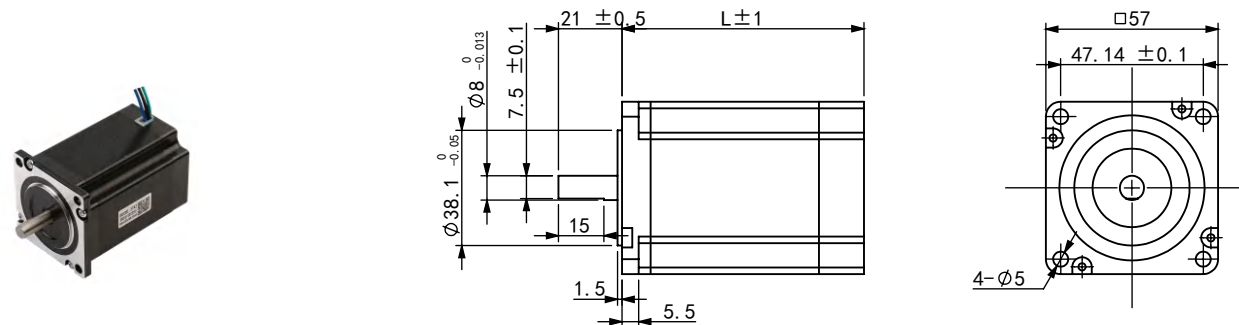

#### Torque-frequency Curve

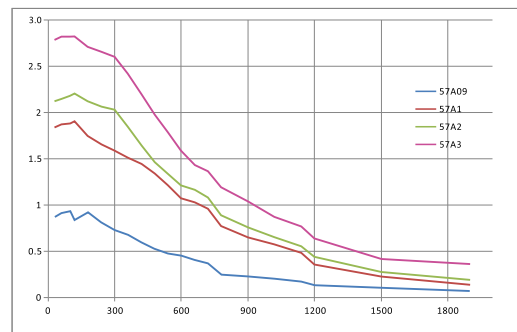

Drive: R60  
Voltage: 36VDC  
Current: Rated  
Micro-stepping: 1600

#### Wiring

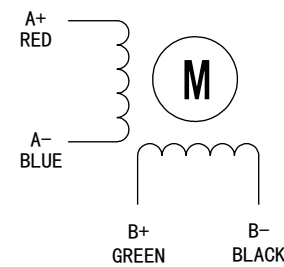

### 2-Phase Stepper Motor 60mm Series Technical Specifications

Model	Step angle (°)	Holding torque(N.m)	Rated current(A)	Resistance/Phase(Ohm)	Inductance/Phase(mH)	Rotor inertia (g.cm <sup>2</sup> )	Shaft diameter(mm)	Shaft length (mm)	Length (mm)	Weight (kg)
60AM21	1.8	2.1	5.0	0.35	1.3	330	8	21	58	0.87
60AM30	1.8	3.0	5.0	0.50	2.2	690	8	21	86	1.39
60AM40	1.8	4.0	5.0	0.86	3.5	880	10	30	102	2.05

\*NEMA 24 (60mm)

#### 60AM21/60AM30 Dimension (mm)

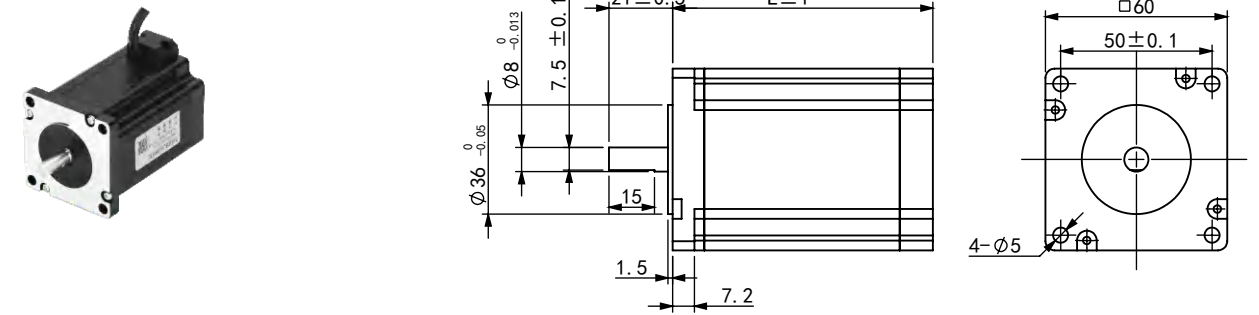

#### 60AM40 Dimension (mm)

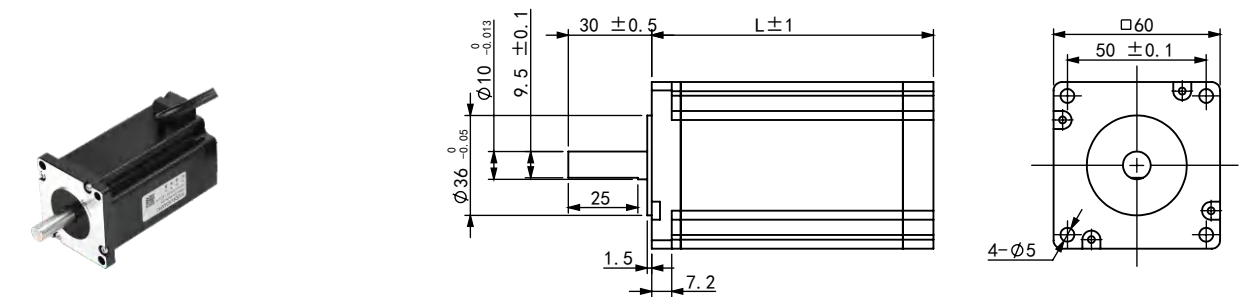

#### Torque-frequency Curve

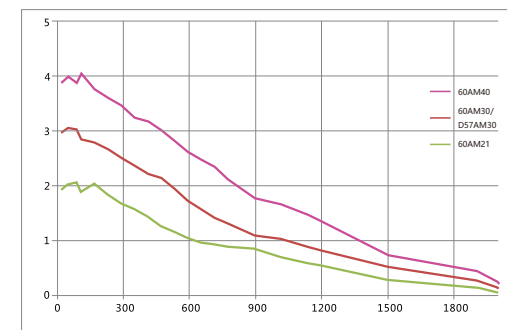

Drive: R60  
Voltage: 48VDC  
Current: Rated  
Micro-stepping: 1600

#### Wiring

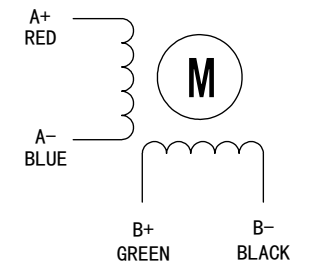

## 2-Phase Stepper Motor 86mm Series Technical Specifications

Model	Step angle (°)	Holding torque(N.m)	Rated current(A)	Resistance/Phase(Ohm)	Inductance/Phase(mH)	Rotor inertia (g.cm <sup>2</sup> )	Shaft diameter(mm)	Shaft length (mm)	Length (mm)	Weight (kg)
86AM35	1.8	3.5	4.0	0.81	3.87	800	9.5	32	64	1.70
86AM45	1.8	4.5	6.0	0.41	2.82	1400	12.7	32	78	2.25
86AM65	1.8	6.5	6.0	0.47	4.18	2300	12.7	32	98	2.95
86AM85	1.8	8.5	6.0	0.53	5.54	2800	12.7	32	112	3.67
86AM120	1.8	12	6.0	1.72	8.30	4000	15.875	32	155	5.10
86AM45-14	1.8	4.5	6.0	0.41	2.82	1400	14	32	78	2.25
86AM65-14	1.8	6.5	6.0	0.47	4.18	2300	14	32	98	2.95
86AM85-14	1.8	8.5	6.0	0.53	5.54	2800	14	32	112	3.67
86AM100	1.8	10	6.0	0.75	5.30	3400	14	32	128	4.10
86AM120-14	1.8	12	6.0	1.72	8.30	4000	14	32	155	5.10

\*NEMA 34 (86mm)

### 86AM35 Dimension (mm)

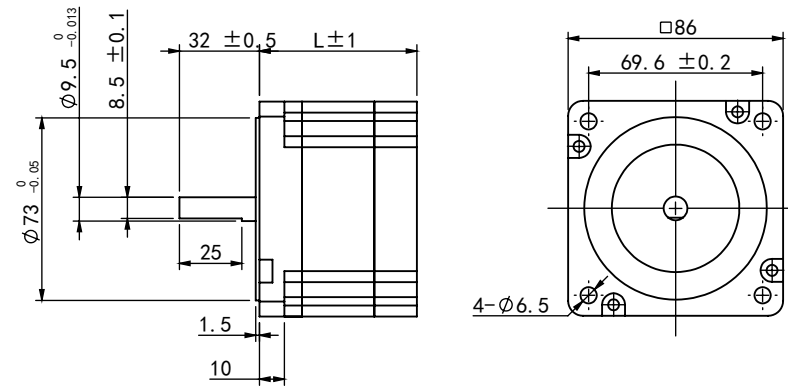

### 86AM45 Dimension (mm)

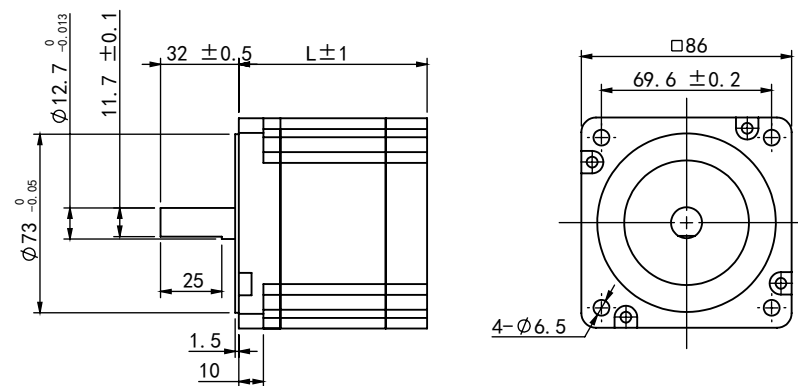

### 86AM65/86AM85 Dimension

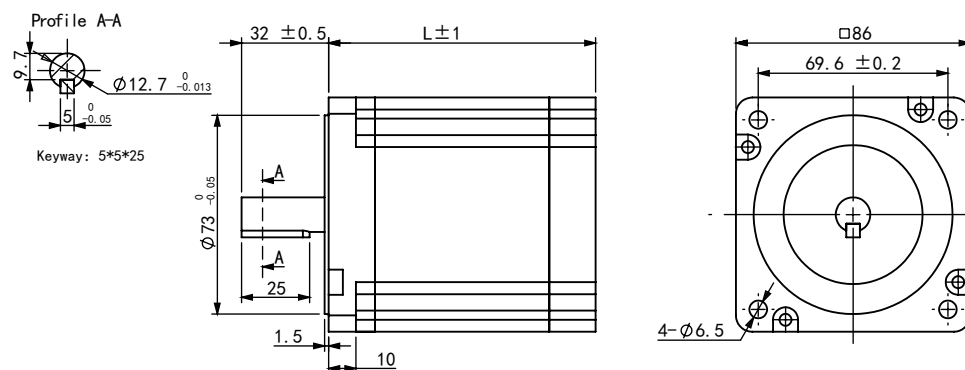

### 86AM120 Dimension (mm)

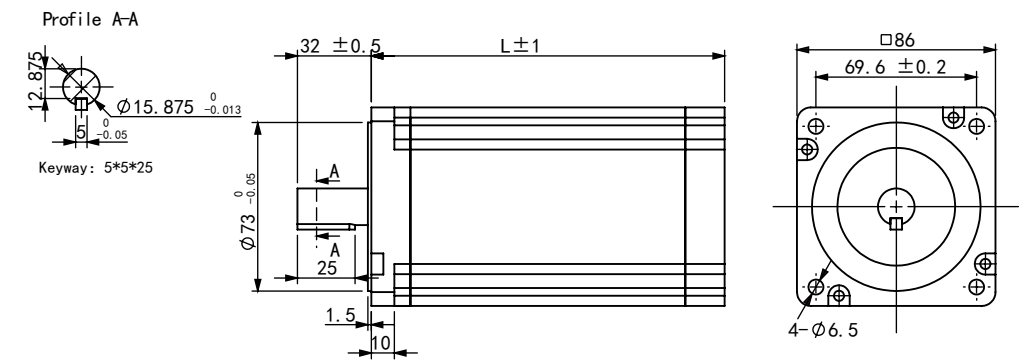

### 86AM-14 Dimension (mm)

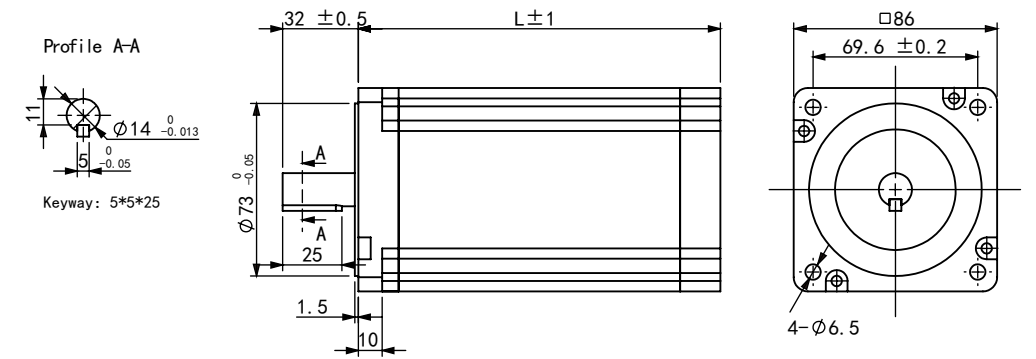

### Torque-frequency Curve

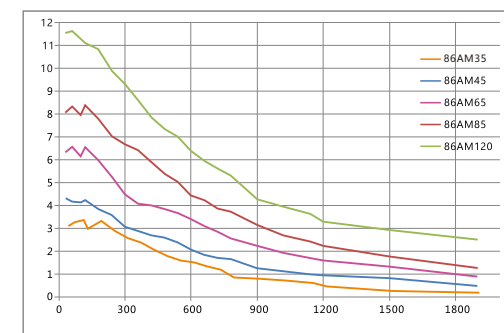

Drive: R86  
Voltage: 60VDC  
Current: Rated  
Micro-stepping: 1600

### Wiring

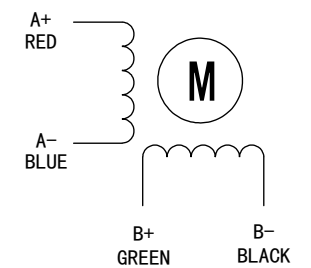

## 2-Phase Stepper Motor 110/130mm Series Technical Specifications

Model	Step angle (°)	Holding torque(N.m)	Rated current(A)	Resistance/Phase(Ohm)	Inductance/Phase(mH)	Rotor inertia (g.cm <sup>2</sup> )	Shaft diameter(mm)	Shaft length (mm)	Length (mm)	Weight (kg)
110A12	1.8	12	6.0	0.37	4.9	7200	19	56	115	6.0
110A20	1.8	20	6.0	0.80	15.0	11000	19	56	150	8.4
110A28	1.8	28	6.5	1.20	22.0	16200	19	56	201	11.7
130A27	1.8	27	6.0	0.65	13.8	35000	19	45	226	13.0
130A45	1.8	45	7.0	0.90	9.5	48400	19	45	283	19.0

\*NEMA 42 (110mm), NEMA 52 (130mm)

### 110A series Dimension (mm)

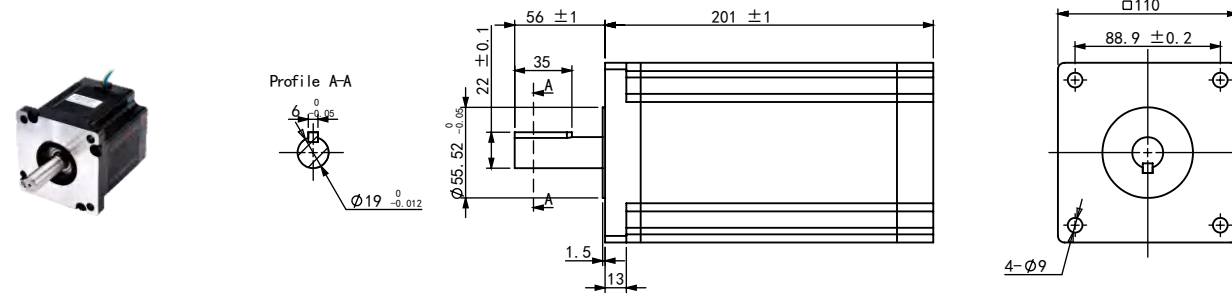

### Torque-frequency Curve

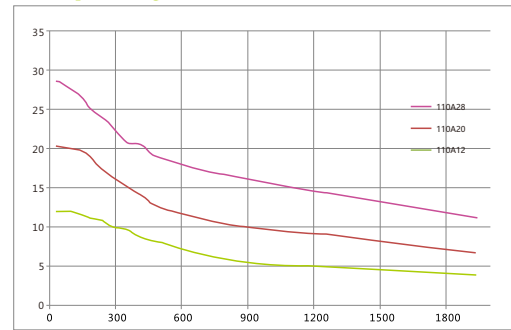

Drive: R110PLUS Voltage: 220VDC  
Current: Rated Micro-stepping: 1600

### Wiring

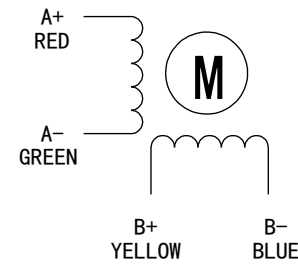

### 130A Series Dimension (mm)

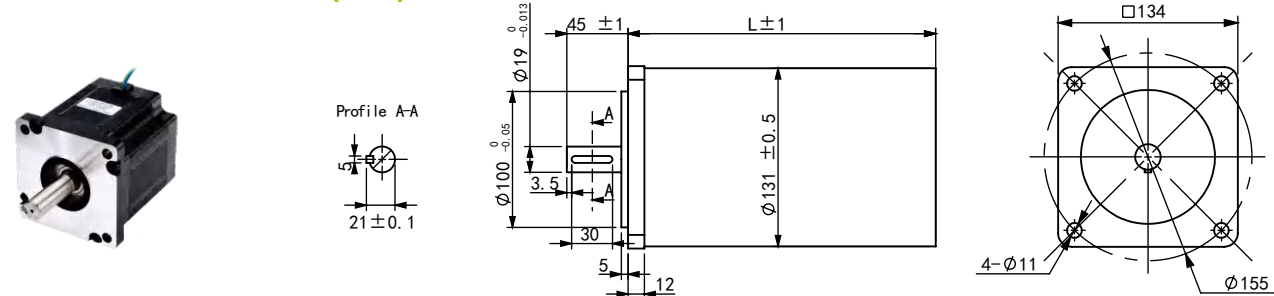

### Torque-frequency Curve

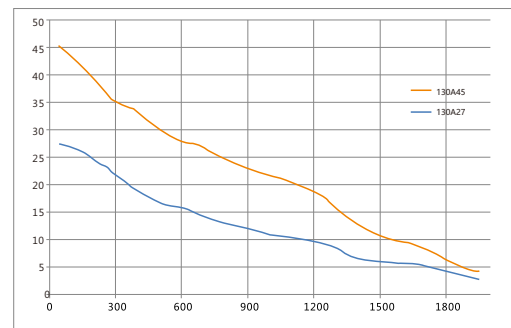

Drive: R130 Voltage: 220VAC  
Current: Rated Micro-stepping: 2000

### Wiring

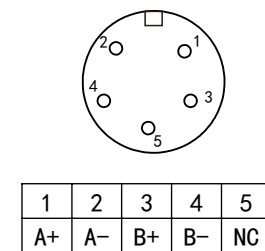

## 3-Phase Stepper Motor 57mm Series Technical Specifications

Model	Step angle (°)	Holding torque(N.m)	Rated current(A)	Resistance/Phase(Ohm)	Inductance/Phase(mH)	Rotor inertia (g.cm <sup>2</sup> )	Shaft diameter(mm)	Shaft length (mm)	Length (mm)	Weight (kg)
57BM09	1.2	0.9	3.5	0.50	1.2	260	8	30	55	0.67
57BM15	1.2	1.5	3.5	0.69	1.8	480	8	30	78	1.10

\*NEMA 23 (57mm)

### 57BM09 Dimension (mm)

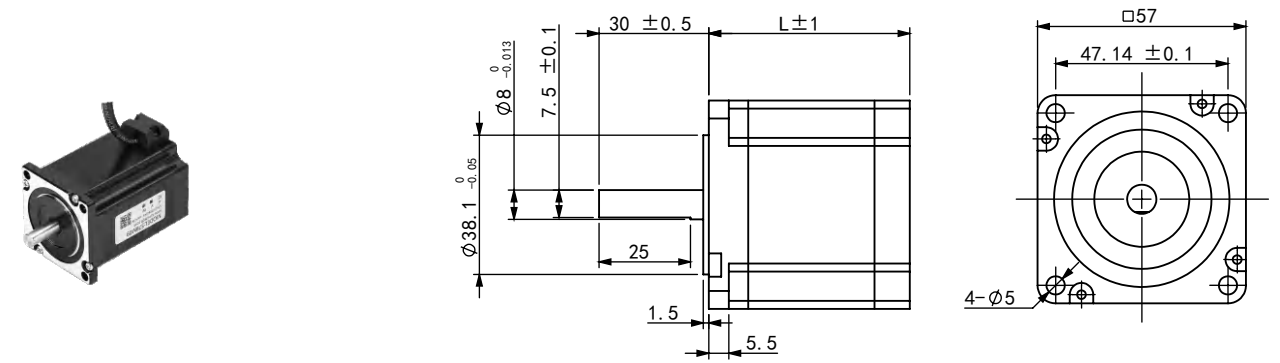

### 57BM15 Dimension (mm)

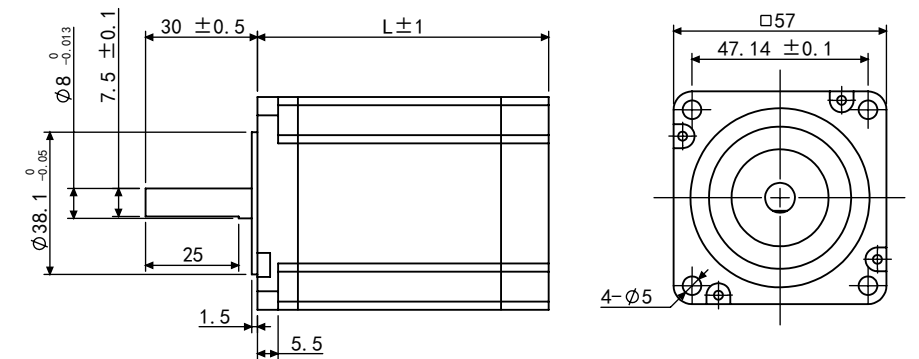

### Torque-frequency Curve

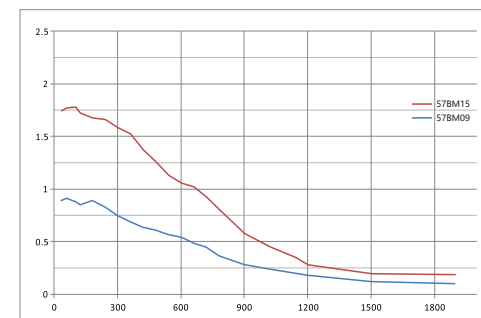

Drive: 3R60 Voltage: 36VDC  
Current: Rated Micro-stepping: 1600

### Wiring

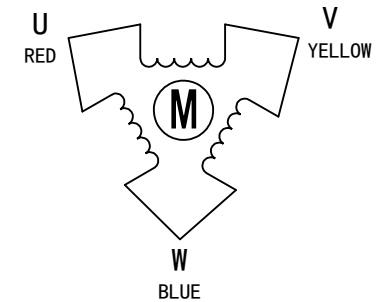

### 3-Phase Stepper Motor 86mm Series Technical Specifications

Model	Step angle (°)	Holding torque(N.m)	Rated current(A)	Resistance/Phase(Ohm)	Inductance/Phase(mH)	Rotor inertia (g.cm <sup>2</sup> )	Shaft diameter(mm)	Shaft length (mm)	Length (mm)	Weight (kg)
86BM20	1.2	2.3	3.0	2.1	7.7	1300	12	32	73	2.0
86BM40	1.2	4.3	4.5	1.1	4.5	2500	12	32	105	2.0
86BM70	1.2	7.0	3.0	4.4	20	3400	14	32	129	4.1
86BM90	1.2	9.0	3.0	5.7	29	4000	14	32	155	5.1

\*NEMA 34 (86mm)

#### 86BM20/86BM40尺寸(mm)

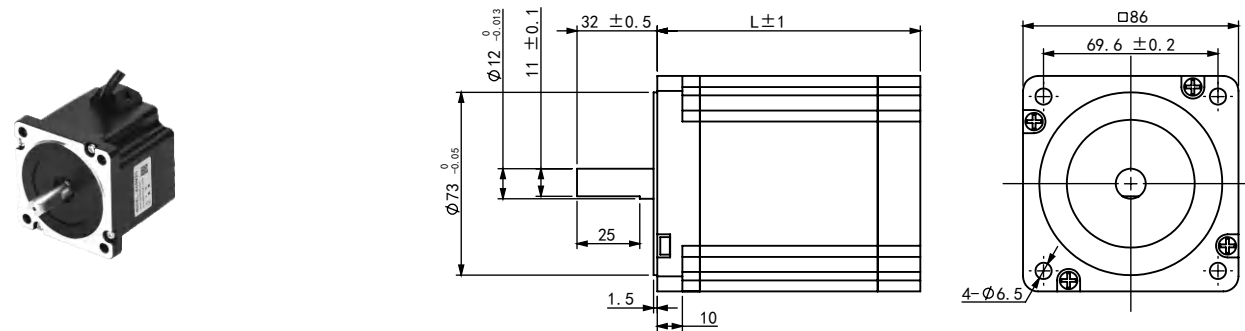

#### 86BM70/86BM90尺寸(mm)

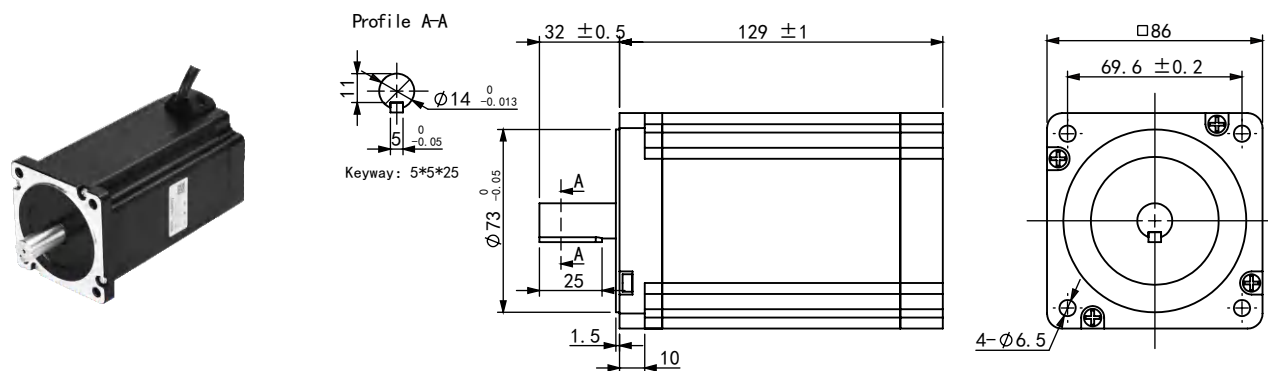

#### Torque-frequency Curve

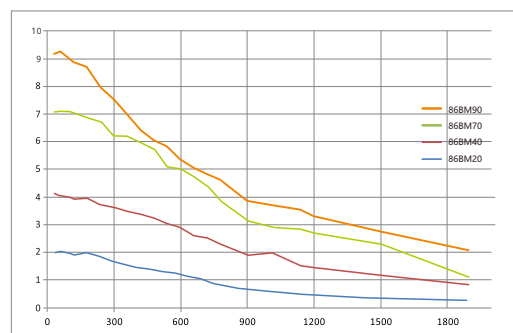

Drive: 3R110PLUS V3.0 Voltage: 220VAC  
Current: Rated Micro-stepping: 2000

#### Wiring

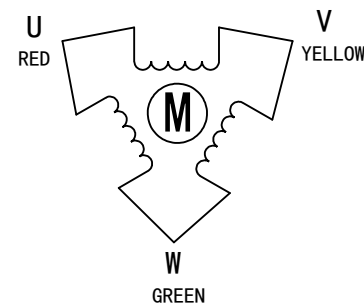

### 3-Phase Stepper Motor 110mm Series Technical Specifications

Model	Step angle (°)	Holding torque(N.m)	Rated current(A)	Resistance/Phase(Ohm)	Inductance/Phase(mH)	Rotor inertia (g.cm <sup>2</sup> )	Shaft diameter(mm)	Shaft length (mm)	Length (mm)	Weight (kg)
110BM80	1.2	8.0	4.3	1.0	11.9	8600	19	40	137	5.5
110BM120	1.2	12	6.0	1.1	12.4	11900	19	40	161	7.1
110BM160	1.2	16	6.5	1.3	19.0	14800	19	40	185	10.7
110BM200	1.2	20	7.0	1.7	22.0	19800	19	40	220	11.0

\*NEMA 42 (110mm)

#### 110BM Series Dimension (mm)

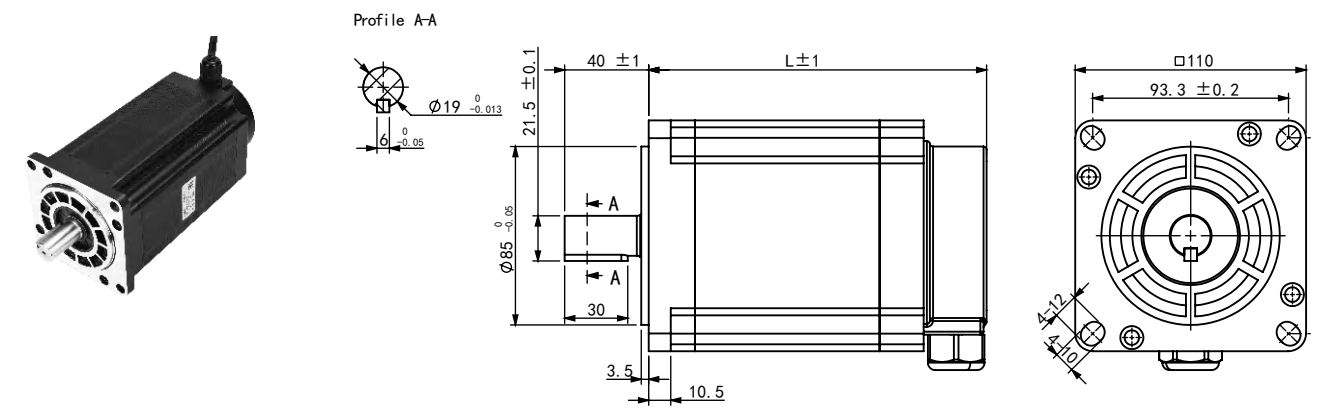

#### Torque-frequency Curve

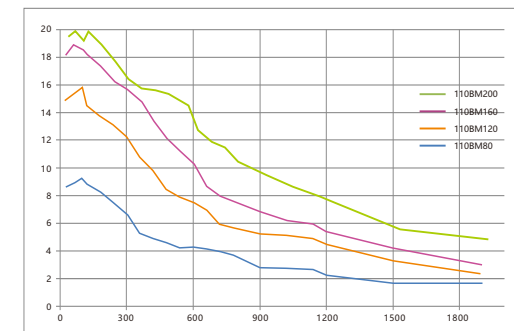

Drive: 3R110PLUS Voltage: 220VAC  
Current: Rated Micro-stepping: 2000

#### Wiring

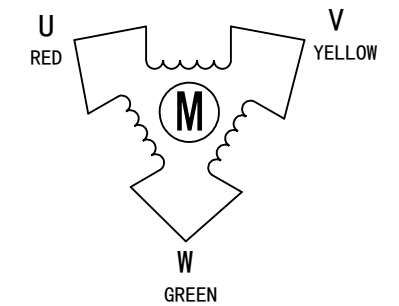

PE: Yellow-Green

### 3-Phase Stepper Motor 130mm Series Technical Specifications

Model	Step angle (°)	Holding torque(N.m)	Rated current(A)	Resistance/Phase(Ohm)	Inductance/Phase(mH)	Rotor inertia (g.cm <sup>2</sup> )	Shaft diameter(mm)	Shaft length (mm)	Length (mm)	Weight (kg)
130B23	1.2	23	5.0	0.95	9.5	26800	19(K5)	45	170	13.7
130B36	1.2	36	5.0	1.30	13.1	35000	19(K5)	45	226	18.4
130B50**	1.2	50	5.0	1.70	18.0	45500	19(K5)	45	282	22.8
130B50**	1.2	50	6.0	0.99	18.3	42500	19(K6)	44	271	16.5

\*NEMA 52 (130mm)

\*\*We have two specifications of 130B50, Please confirm before ordering.

#### K5: 130B Series Dimension (mm)

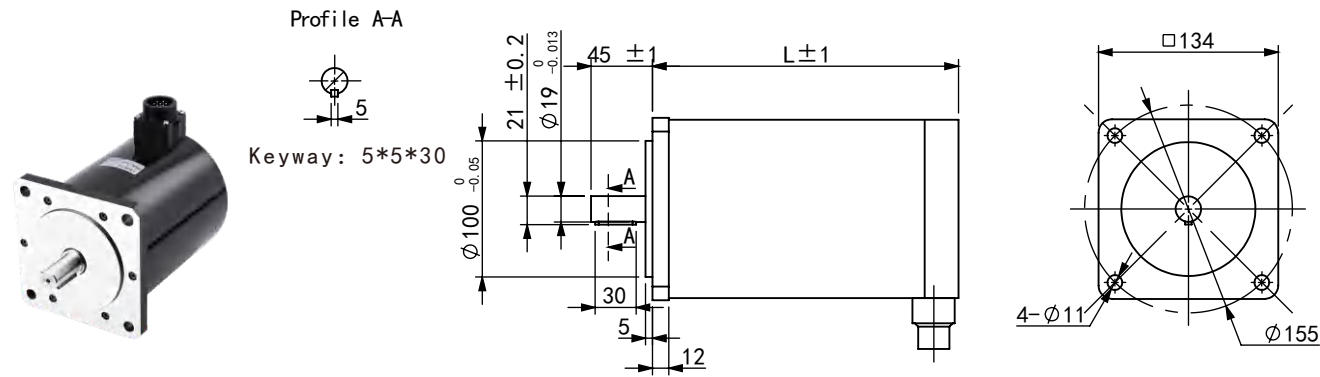

#### K6: 130B50 Series Dimension (mm)

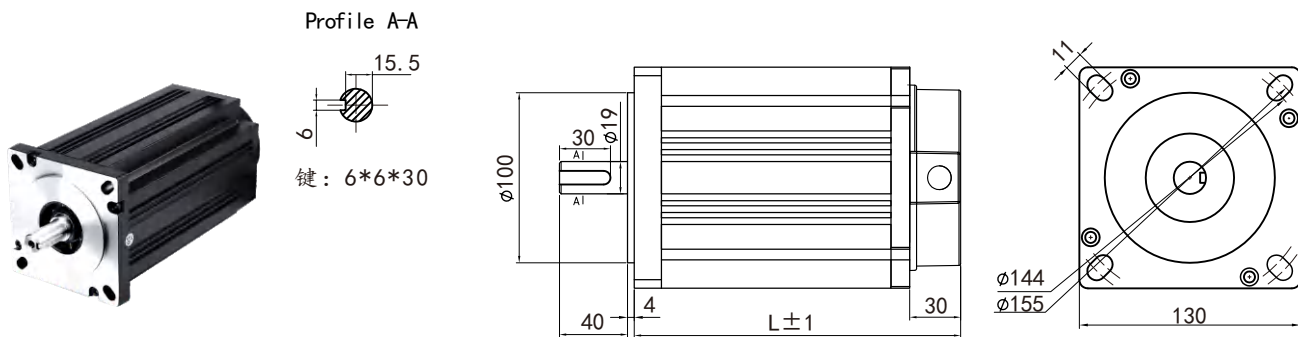

#### Torque-frequency Curve

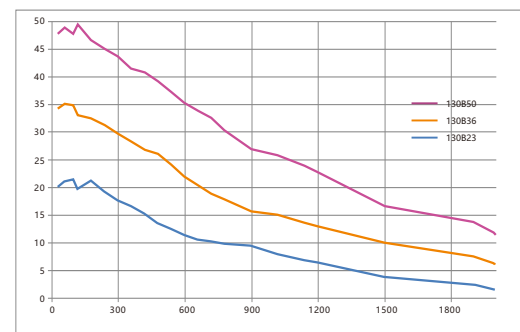

Drive: 3R130 Voltage: 220VAC  
Current: Rated Micro-stepping: 2000

#### Wiring

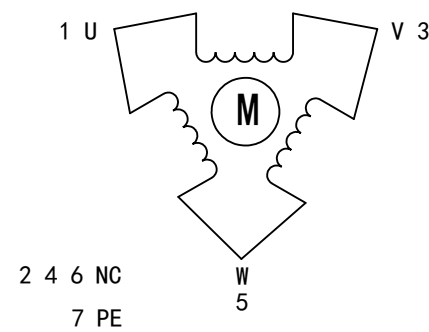

### 5-phase stepping motor

Model	Step angle (°)	Holding torque(N.m)	Rated current(A)	Resistance/Phase(Ohm)	Inductance/Phase(mH)	Rotor inertia (g.cm <sup>2</sup> )	Shaft diameter(mm)	Shaft length (mm)	Length (mm)	Weight (kg)
42C03	0.72	0.3	0.75	1.9	1.6	68	5	24	48	0.3
60C1	0.72	1.0	1.5	0.5	1.2	380	8	21	64	0.9
60C2	0.72	1.3	1.5	3.6	9.7	550	8	21	76	1.1

#### NEMA 17(42mm) Series Dimensions

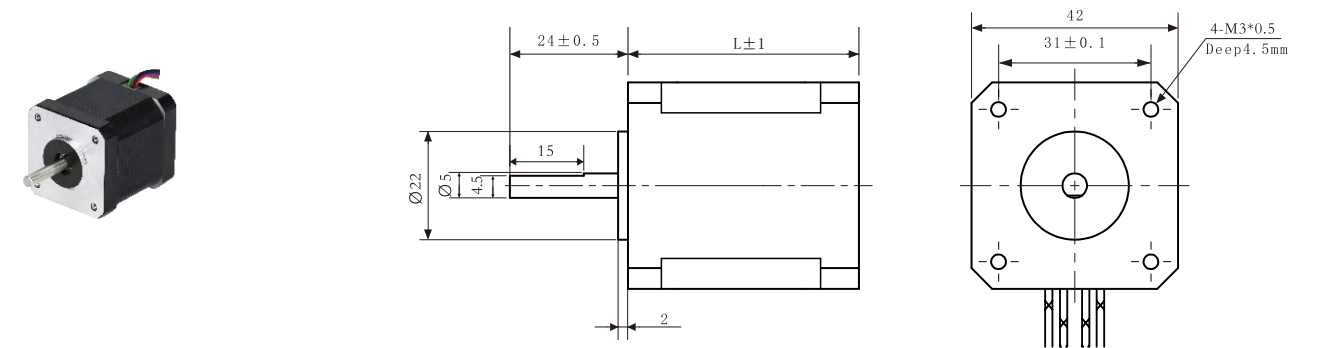

#### NEMA 24(60mm) Series Dimensions (mm)

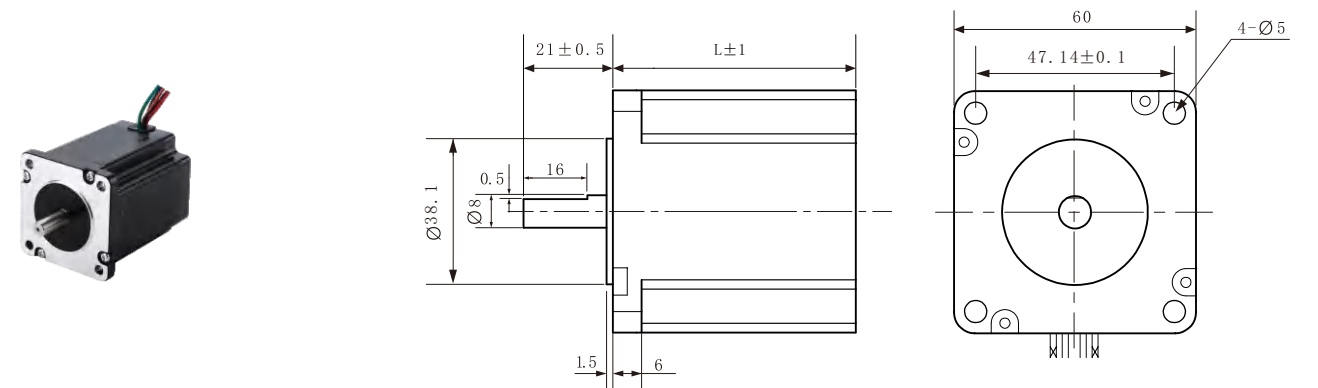

#### Torque-frequency Curve

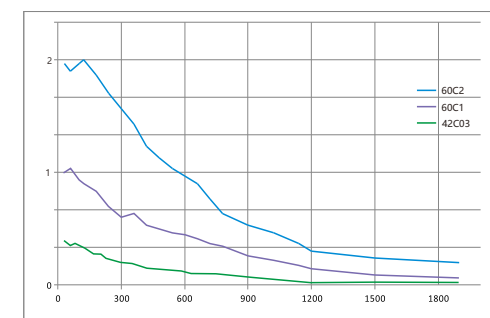

Drive: 5R42/5R60 Voltage: 36VDC  
Current: Rated Micro-stepping: 2000

#### Wiring

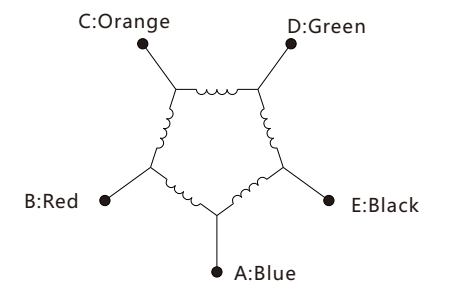

# Reducer for Stepper Motor

## Transmission Stepper Reducer

Model	Input dimension (Motor insertion end)				Output dimension (Client installation end)				Length	
	Shaft diameter	Boss diameter	Mounting hole distance	Mounting hole size	Shaft diameter	Boss diameter	Mounting hole distance	Mounting hole size	L1	L2
42PRF-□*	5	22	31.0	3.5	8	25	P.C.D.35	M4	43	53
57PLF-□*	8	38	47.1	M4	14	40	47.1	5.5	53	70
86PLF-□*	14	73	69.6	M6	14	73	69.6	M6	83	97

\*PRF and PLF series reducer input terminal has size limitation, some stepper motors need to be cut shaft before assembly

### 42PRF Series Dimensions (mm)

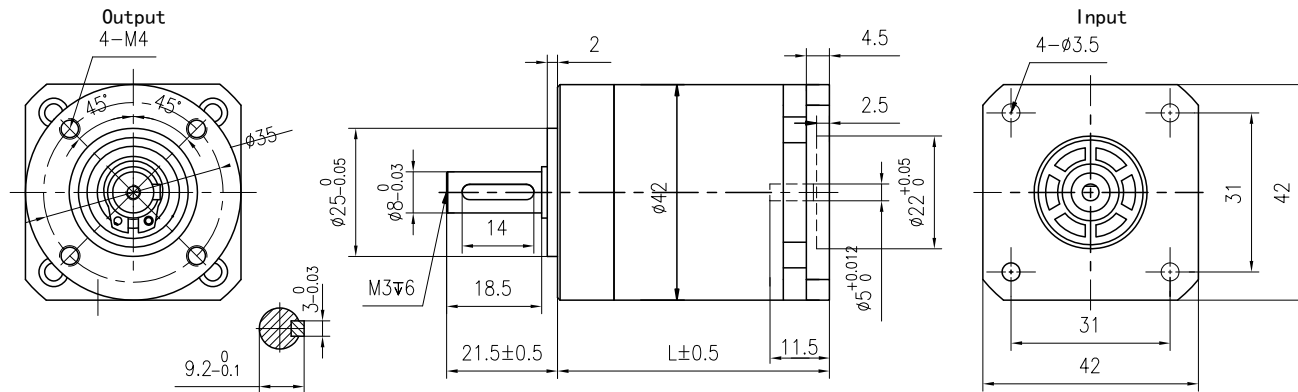

### 57PLF Series Dimensions (mm)

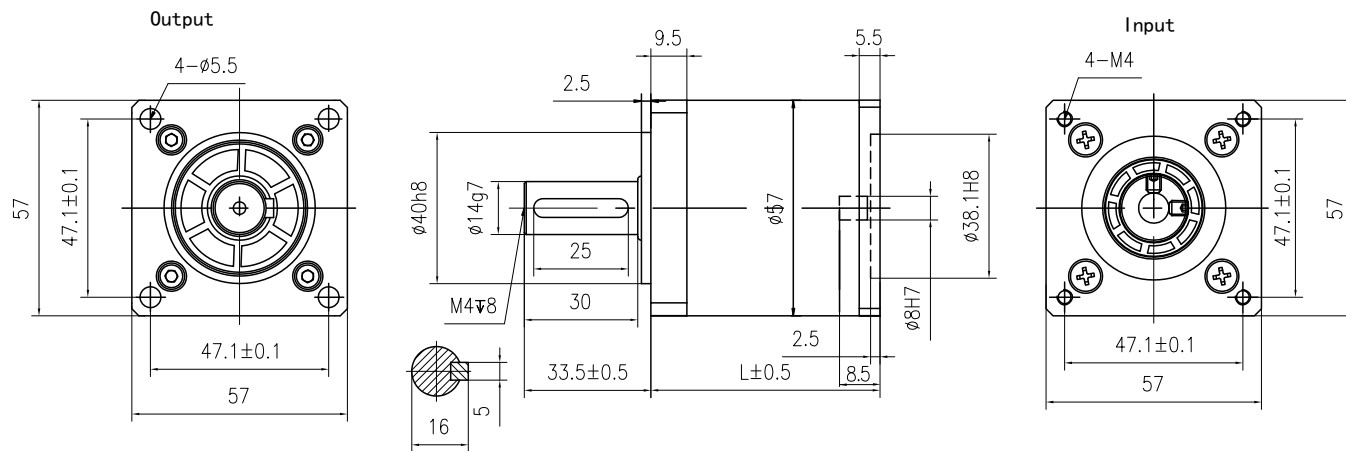

### 86PLF Series Dimensions (mm)

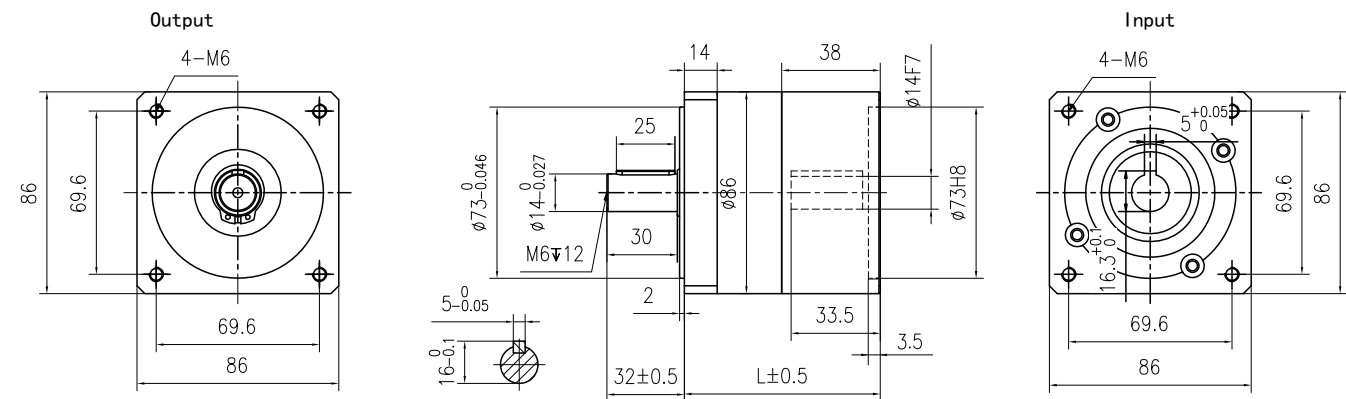

## Precision Stepper Reducer

Model	Input dimension (Motor insertion end)				Output dimension (Client installation end)				Length	
	Shaft diameter	Boss diameter	Mounting hole distance	Mounting hole size	Shaft diameter	Boss diameter	Mounting hole distance	Mounting hole size	L1	L2
42PLX-□	5	22	31.0	3.5	10	35	P.C.D.50	3.5	62	77
60PLX-□	8	38	47.1	M4	14	50	P.C.D.70	5.5	77	95
90PLX-□	14	73	69.6	M6	20	80	P.C.D.100	6.5	110	130

\*The L1 reducer can have a reduction ratio range of 3-10, the L2 reducer can have a reduction ratio range of 15-100.

### 42PLX Series Dimensions (mm)

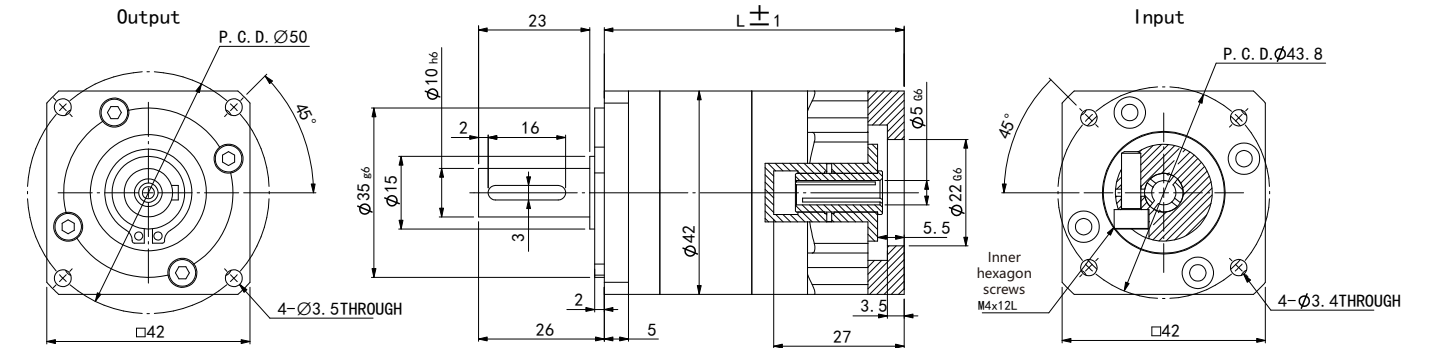

### 60PLX Series Dimensions (mm)

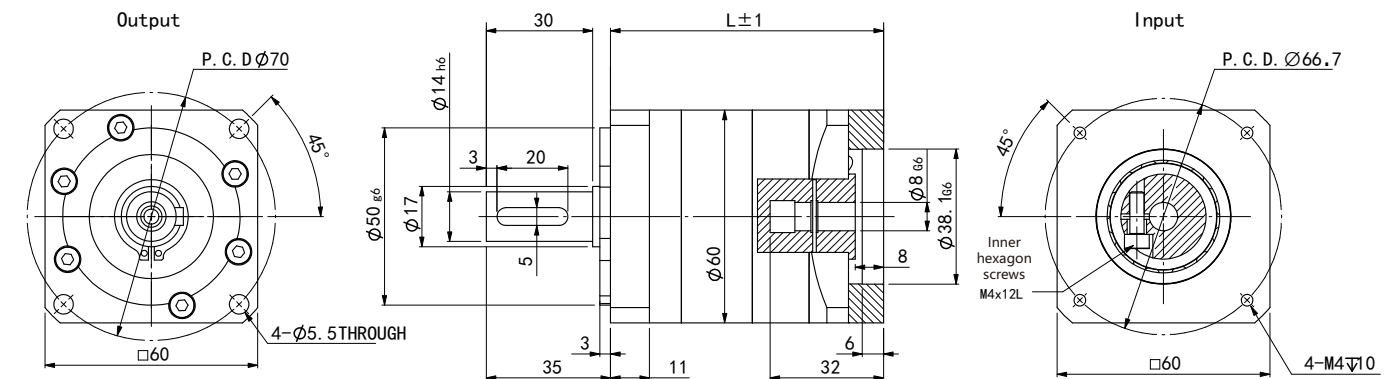

### 90PLX Series Dimensions (mm)

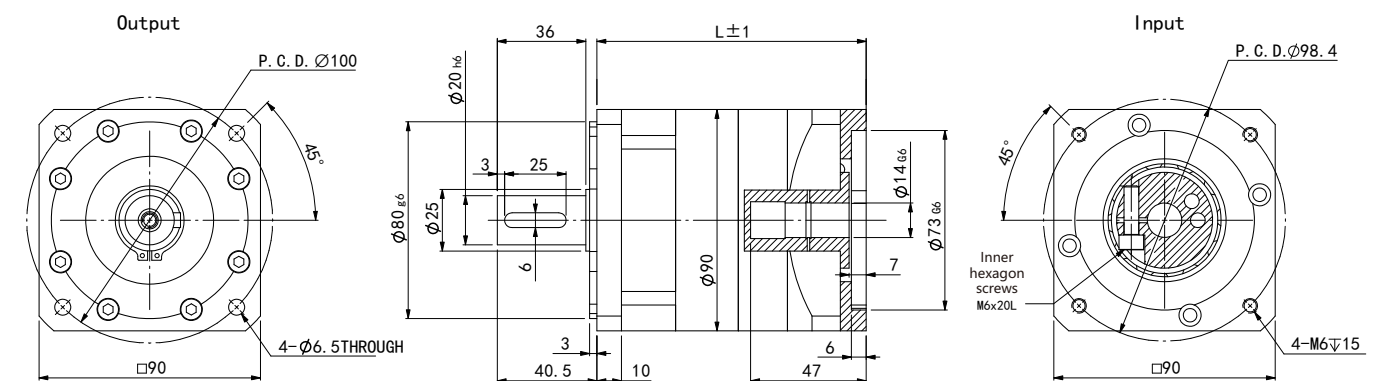

# Integrated Stepper Motor IR/IT Series

The integrated stepper motor is a perfect combination of motor, encoder and drive. The product has multiple control methods, which not only saves installation space, but also makes wiring convenient and reduces labor costs.



RS485      Pulse command      IO command

- 01 Three in one, motor, encoder, and driver
- 02 Low heat, high torque, high speed
- 03 Space saving and convenient wiring

# Product Highlights

The IR/IT series is an intelligent integrated stepper motor launched by Rtelligent. The existing products cover 42mm-86mm base motor. It not only supports external pulse and communication control, but also can achieve motion control through internal self-programming.

- Pulse control methods: pulse + direction, double pulse, orthogonal pulse
- Communication control mode: Rs485
- Communication Settings: 5-digit dip code - 31 axis addresses; 2-digit dip code - 4 baud rates
- Motion direction setting: A 1-digit dip code is used to set the motor's running direction
- Control signal: 5V or 24V single-ended input, common anode connection method



## Naming Rule

IT 42 AM 06 \_ D 08 24 \_ 5V \_ M  
 ① ② ③ ④ ⑤ ⑥ ⑦ ⑧ ⑨

① Series name IR: Integral open loop series IT: Integral closed loop series	② Motor frame size 20mm、28mm、42mm、 57mm、60mm、86mm	③ Motor version
④ Motor torque 06: 0.6N·m	⑤ Motor shaft type D: Single flat K: Keyed G: Plain shaft	⑥ Shaft diameter Unit: mm
⑦ Shaft length Unit: mm	⑧ IO signal level 5V、24V	⑨ Communication interface M: Modbus - RS485 C: Can - CanOpen E: EtherCAT

\*注意：信号电平 5V 和 24V 的产品型号不同，选型时请核对无误。

### Technical Specifications

Frame size	Model	Voltage(V)	Current(A)	Rated Torque (N·m)	Shaft Length (mm)	Shaft Diameter (mm)	Body Length L(mm)		
42	IT42AM04-D0524-24V-M	12~24VDC	1.5	0.4	24	5	57		
	IT42AM06-D0524-24V-M			0.6			64		
	IT42AM08-D0524-24V-M			0.8			77		
57	IT57AM13-D0824-24V-M	18~50VDC	3.0	1.3	24	8	81.5		
	IT57AM23-D0824-24V-M		5.0	2.3			102.5		
	IT57AM30-D0824-24V-M		5.0	3.0			111.5		
D57	ITD57AM30-D0821-24V-M	18~50VDC	5.0	3.0	21	8	112.5		
	ITD57AM40-D1030-24V-M			4.0	30		10	128.5	
60	IT60AM30-D0821-24V-M			3.0	21	8	112.5		
	IT60AM40-D1030-24V-M							4.0	30
86	IT86AM45-K1440-24V-M			6.0	40	4.5	14	14	108.5
	IT86AM85-K1440-24V-M					8.5			142.5
	IT86AM120-K1440-24V-M	12.0	185.5						

### • 42 series

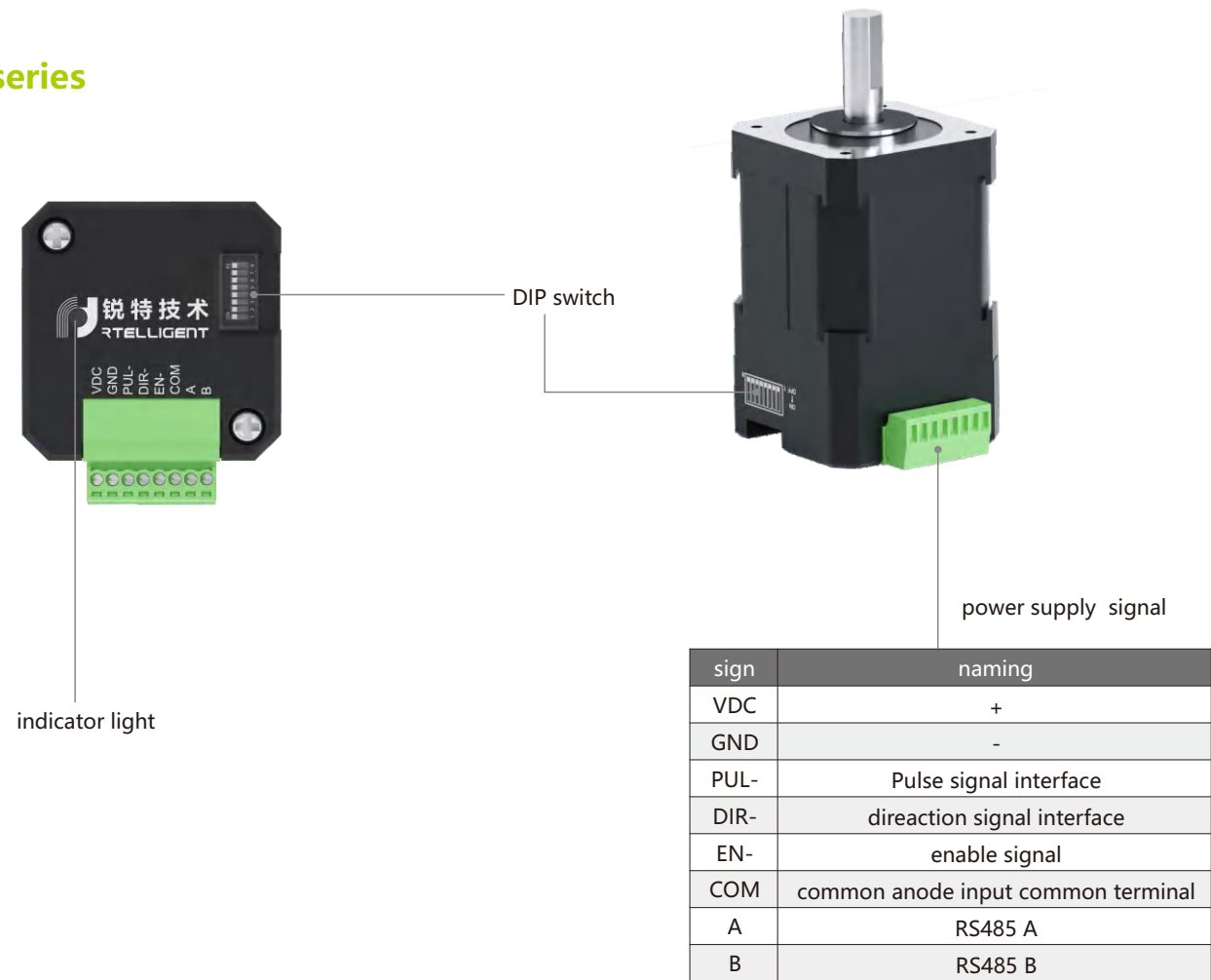

### • 57/D57/60 series

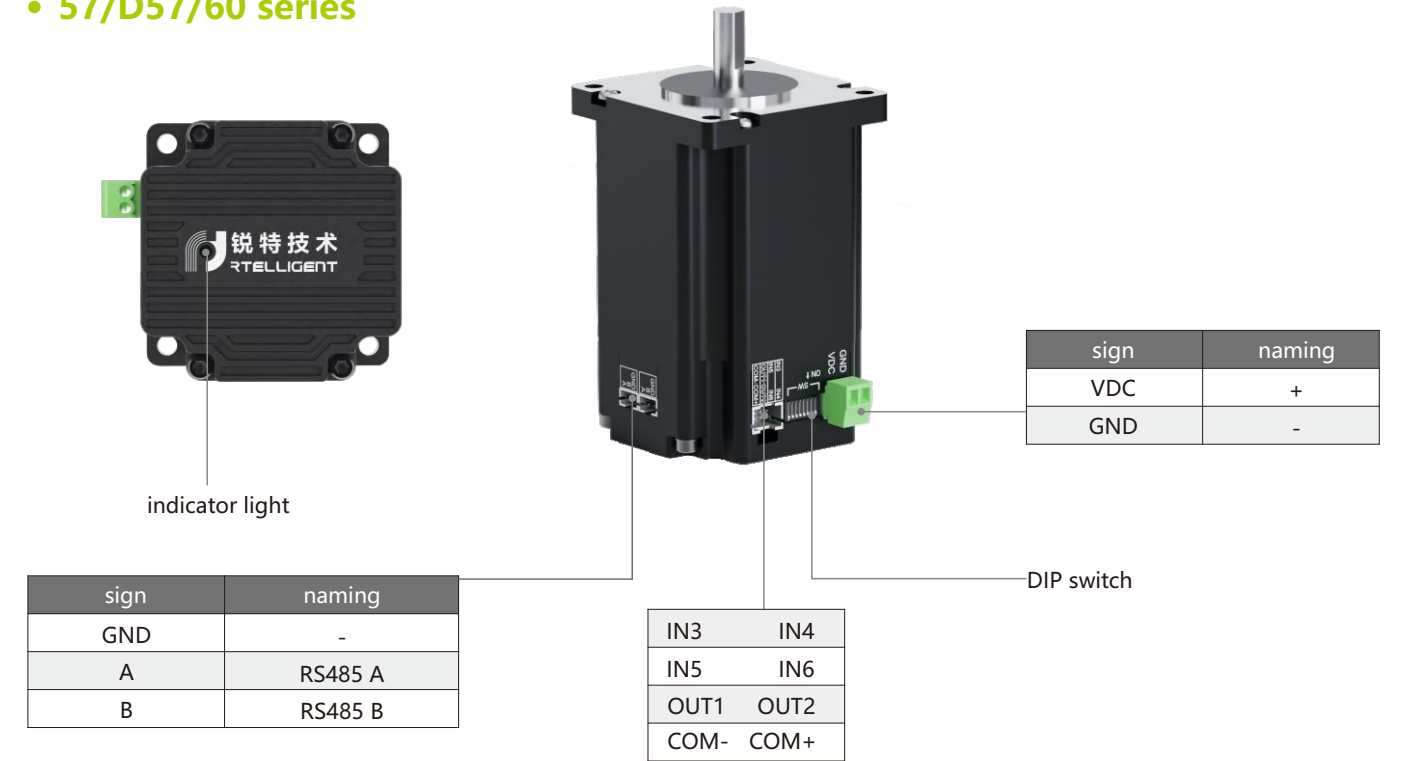

### • 86 series

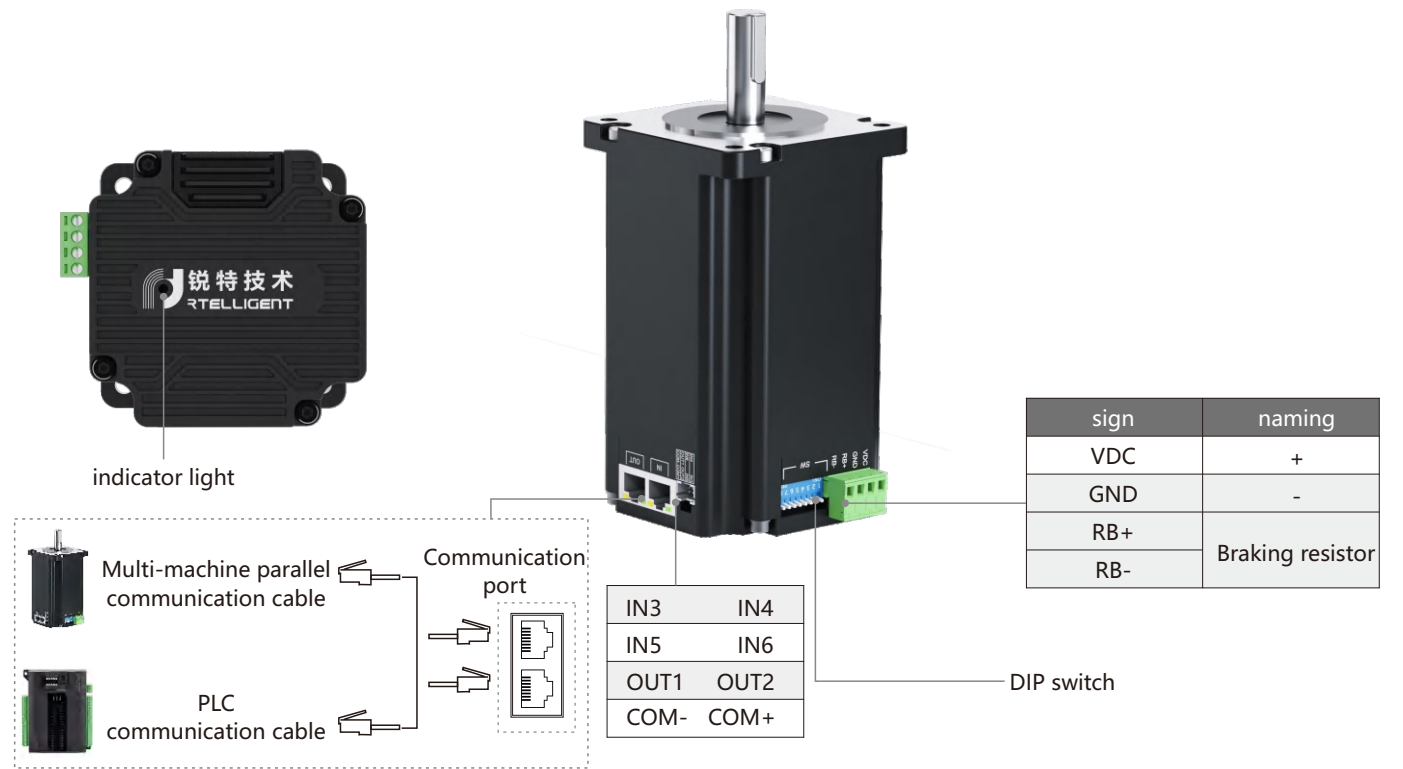

1. The working voltage range of the product shall be based on the actual identification, otherwise it will damage the product.
2. Users need to clearly know whether the connected signal level is 5V or 24V, otherwise it may damage the IO port.
3. RS485 communication interface, isn't isolated, using GND as the reference ground.

42mm Series Size

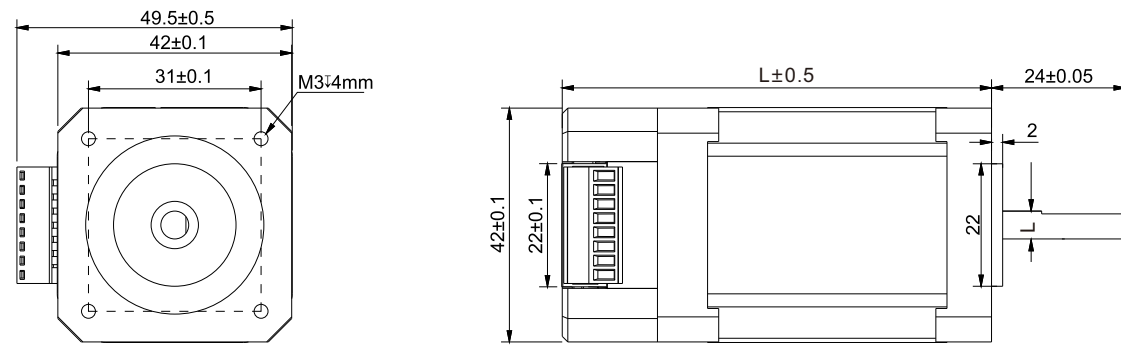

D57mm Series Size

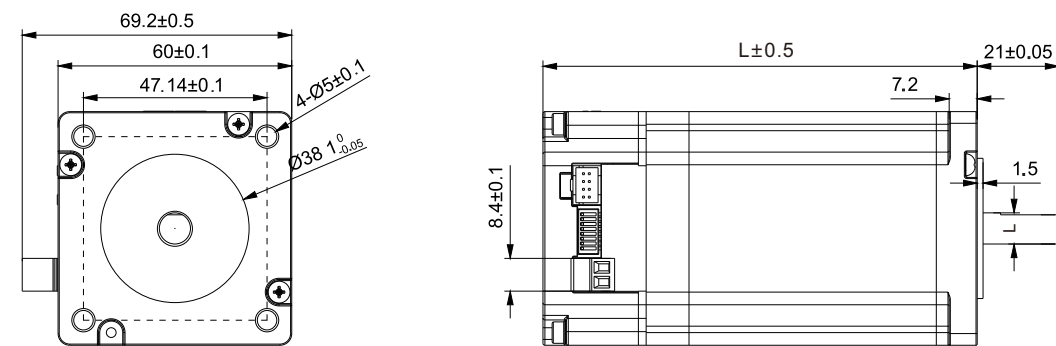

60mm Series Size

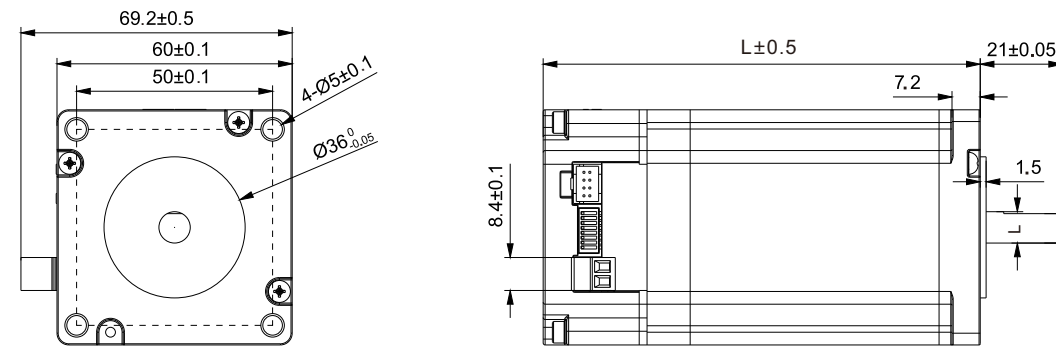

86mm Series Size

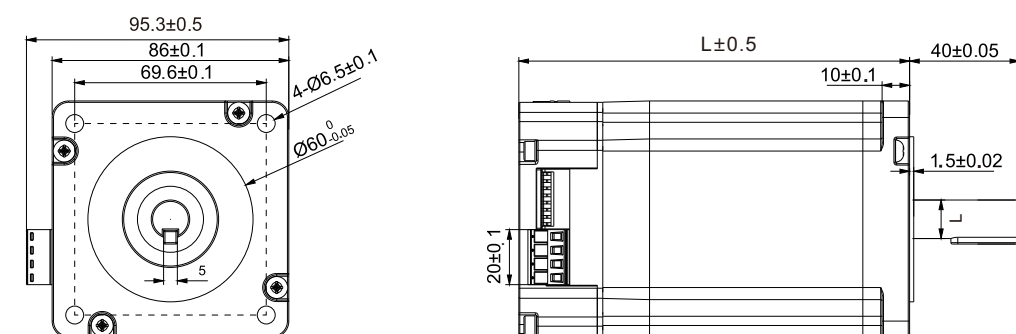

Slave Station address

Slave Station	SW1	SW2	SW3	SW4	SW5
Default	ON	ON	ON	ON	ON
1	OFF	ON	ON	ON	ON
2	ON	OFF	ON	ON	ON
3	OFF	OFF	ON	ON	ON
4	ON	ON	OFF	ON	ON
.....	.....	.....	.....	.....	.....
30	ON	OFF	OFF	OFF	OFF
31	OFF	OFF	OFF	OFF	OFF

Baud Rate Setting

BDR	SW6	SW7
9600	ON	ON
19200	OFF	ON
38400	ON	OFF
115200	OFF	OFF

Direction Setting

SW8	Direction
ON	Forward
OFF	Reverse

By setting the ON or OFF state of SW8, the running direction of the motor can be changed. The factory defaults to the OFF state

LED Indication

LED status	Drive status
●	Steady green light
● ●	Flashing green light
● ● ● ●	1 green, 1 red
● ● ● ● ● ●	1 green, 2 red
● ● ● ● ● ● ● ●	1 green, 3 red
● ● ● ● ● ● ● ● ● ●	1 green, 4 red
● ● ● ● ● ● ● ● ● ● ● ●	1 green, 6 red
● ● ● ● ● ● ● ● ● ● ● ● ● ●	1 green, 7 red

# Bus Stepper Integrated Motor

Rtelligent IT57-E/C Bus type Integrated Stepper Motor integrates an intelligent motion controller. It adopts a standardized bus protocol, offering simplified wiring, strong anti-interference capability, and a more stable and reliable system.

EtherCAT

CANopen



**01**  
Integrated design,  
Space saving

**02**  
Flexible IO interface,  
plug and play

**03**  
DIP switch configuration  
+ Type-C debugging

# IT57-E/C Series

IT57-E/C is a high-performance bus-controlled integrated stepper motor that also integrates intelligent motion controller functionality. The standardized protocol makes the entire control system more stable and reliable, while simplifying on-site wiring and effectively avoiding the command pulse interference issues commonly found in traditional pulse-type drives.



- Control Method: Closed-loop control
- Communication Control Mode: EtherCAT/CANopen
- Supports CoE (CANopen over EtherCAT), compliant with CiA 402 standard
- Encoder: 17-bit magnetic encoder (single-turn or multi-turn optional)
- Digital I/O Ports: 4 channels of optically isolated digital signal input: DI1 to DI4 are 24V single-ended inputs, supporting both NPN and PNP input; 2 channels of optically isolated digital signal output, with a maximum withstand voltage of 30V, and a maximum sink or source current of 100mA, common cathode connection.

## Naming Rule

IT 57 AM 23 - D 08 21 - 24V - E Q

① ② ③ ④ ⑤ ⑥ ⑦ ⑧ ⑨ ⑩

<p><b>① Series name</b> IT: Integral closed loop series</p>	<p><b>② Motor frame size</b> 20mm, 28mm, 42mm, 57mm, 60mm, 86mm</p>	<p><b>③ Motor version</b></p>
<p><b>④ Motor torque</b> 06: 0.6N·m</p>	<p><b>⑤ Motor shaft type</b> D: Single flat K: Keyed G: Plain shaft</p>	<p><b>⑥ Shaft diameter</b> Unit: mm</p>
<p><b>⑦ Shaft length</b> Unit: mm</p>	<p><b>⑧ IO signal level</b> 5V, 24V</p>	<p><b>⑨ Communication interface</b> C: Can – CanOpen E: EtherCAT</p>
		<p><b>⑩ Encoder resolution</b> Omit: Single-turn encoder Q: Multi-turn encoder</p>

### Technical Specifications

Frame size	Communication protocol	Encoder	Model	Voltage (V)	Current (A)	Rated torque (N·m)	Shaft length (mm)	Shaft diameter (mm)	Body length L(mm)	
57	CANopen	Single-turn encoder	IT57AM13-D0821-24V-C	24~60VDC	3.0	1.3	21	8	96.5	
			IT57AM23-D0821-24V-C		5.0	2.3			97.5	
			IT57AM30-D0821-24V-C		5.0	3.0			143.5	
	EtherCAT		Single-turn encoder		IT57AM13-D0821-24V-E	3.0			1.3	96.5
					IT57AM23-D0821-24V-E	5.0			2.3	97.5
					IT57AM30-D0821-24V-E	5.0			3.0	143.5
	CANopen	Multi-turn encoder			IT57AM13-D0821-24V-CQ	3.0			1.3	96.5
					IT57AM23-D0821-24V-CQ	5.0			2.3	97.5
					IT57AM30-D0821-24V-CQ	5.0			3.0	143.5
	EtherCAT		Multi-turn encoder		IT57AM13-D0821-24V-EQ	3.0			1.3	96.5
					IT57AM23-D0821-24V-EQ	5.0			2.3	97.5
					IT57AM30-D0821-24V-EQ	5.0			3.0	143.5

### 57mm Series Size

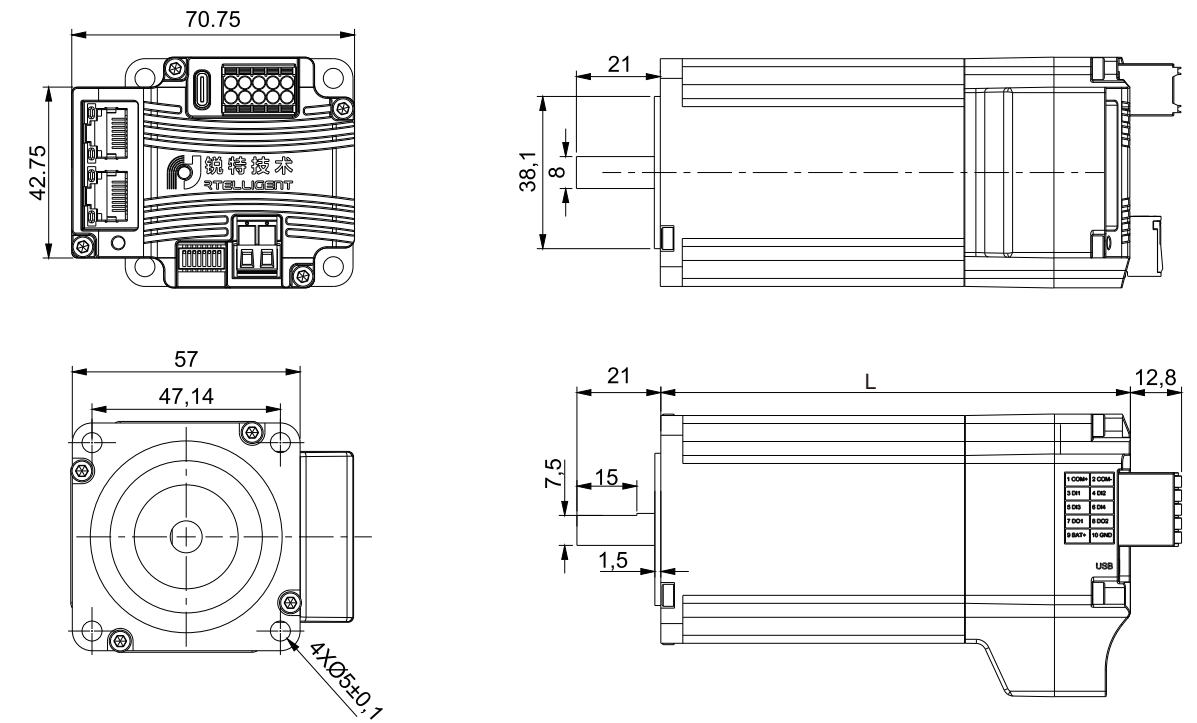

### Port layout

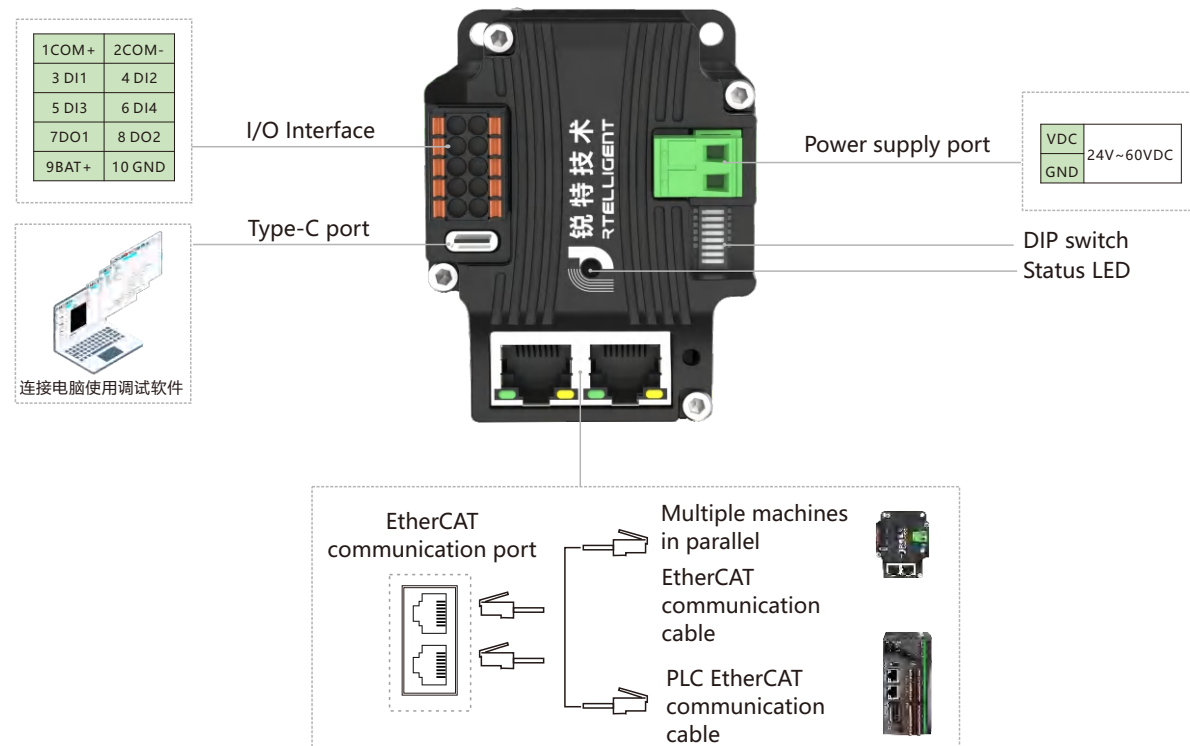

### LED Indication

LED status	Drive status
●	Steady green light Drive is not enabled
● ●	Flashing green light Drive is working properly
● ● ●	1 green, 1 red Drive overcurrent
● ● ● ●	1 green, 2 red Drive input power supply overvoltage
● ● ● ● ●	1 green, 3 red Drive internal voltage error
● ● ● ● ● ●	1 green, 4 red Encoder out-of-tolerance alarm
● ● ● ● ● ● ●	1 green, 6 red Parameter verification error
● ● ● ● ● ● ● ●	1 green, 7 red Motor phase loss alarm
● ● ● ● ● ● ● ● ●	1 green, 8 red Encoder failure

# Linear Stepper Motor

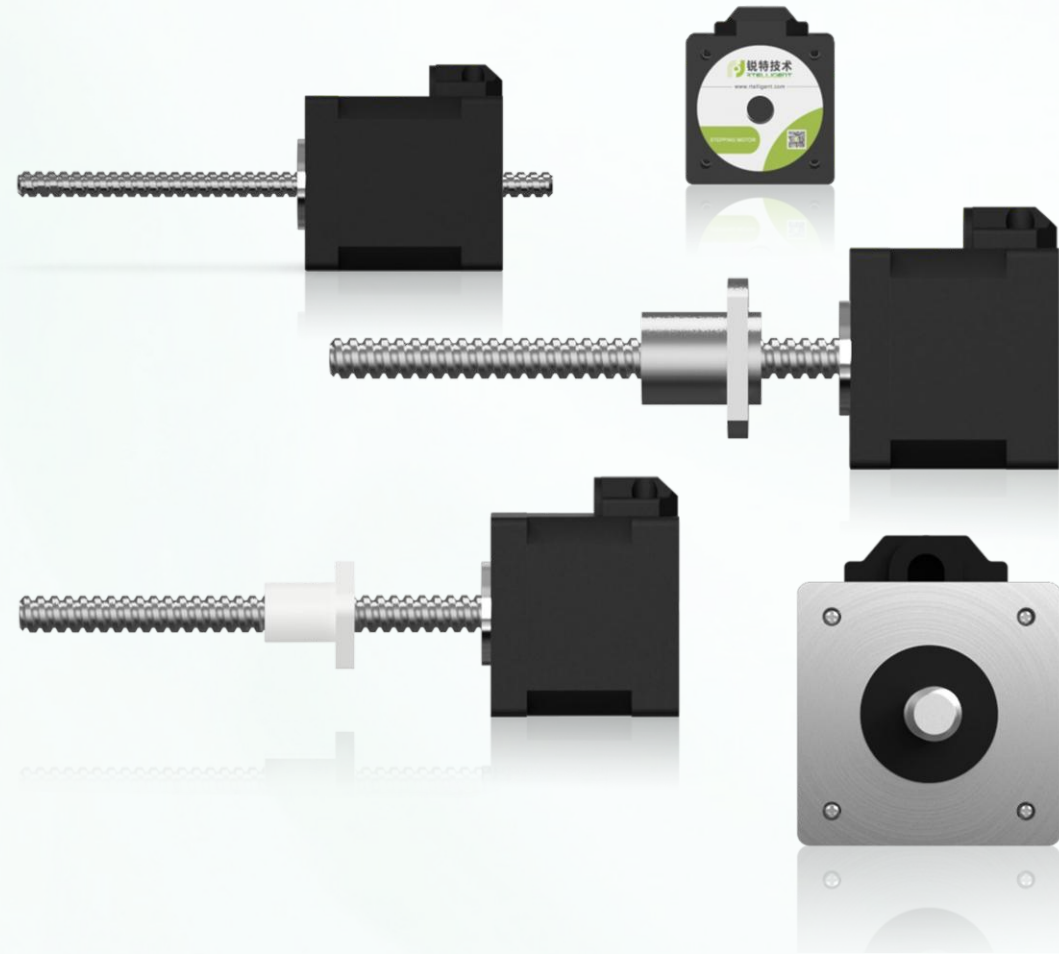

01

### External Nut ACME Screw

- Inch T-shape screw, anti-backlash nuts are optional
- Recommended speed range 300rpm
- Screw transmission efficiency 20-50%
- Brake and closed loop are optional

02

### External Nut Ball Screw

- Rolling ball screw, C7 precision
- Recommended speed range 700rpm (closed loop 1500rpm)
- Screw transmission efficiency 90-98%
- Brake and closed loop are optional

03

### Non-Captive ACME Screw

- Inch T-shape screw
- Recommended speed range 300rpm
- Screw transmission efficiency 20-50%
- Brake and closed loop are not optional

## Naming Rule

57A09 E C - Z - GZ1210 - 3 - 140 - 001

① ② ③ ④ ⑤ ⑥ ⑦ ⑧

① Motor model	② Shaft mode N: Non-Captive E: External Nut	③ Encoder code C: With encoder None: Omitted	④ Break code Z: With break None: Omitted
⑤ Screw type & lead Gz1210: Ball screw, 10mm lead, 12mm diameter 5.08: ACME screw, 5.08mm lead, diameter omitted	⑥ Rated motor current Unit: mm	⑦ Screw length Unit: mm	⑧ Customized Code

\*Model naming rules are only used for model meaning analysis. For specific optional models, please consult with our engineer.

## Technical Specifications

Screw type	Motor frame	Optional motor body length				Optional diameter	Optional lead							
		30	42	48	60		1	2	4	8	10.16	25.4		
ACME	20	30	42			3.5								
	28	34	45			4.76	0.635	1.27	2.54	5.08	10.16			
	35	34	47			6.35	1.27	2.54	6.35	12.7	25.4			
	42	34	40	48	60	6.35	1.27	2.54	6.35	12.7	25.4			
	57	45	55	65	75	9.525	1.27	2.54	5.08	10.16	25.4			
	86	76	114			15.875	2.54	3.175	6.35	12.7	25.4			
Ball	20	30	42			6	1							
	28	34	45			8	1	2						
	35	34	47			8	1	2						
						12	2	5	10					
	42	34	40	48	60	8	1	2						
	57	45	55	65	75	12	2	5	10					
86	76	114			16	5	10	16						

## ■ Concepts

**Lead:** The lead is the linear stroke of the screw when it rotates the nut for one circle.

**Thrust:** Thrust refers to the thrust generated by the motor in the shaft direction of screw. When selecting, the screw thrust should be greater than the sum of the external forces of the current load.

Thrust formula:  $T \cdot 2\pi \cdot \eta = F \cdot B$   
 T: Effective torque  
 Q: Screw transmission efficiency  
 F: Thrust  
 B: Lead

**Screw:** The ball screw uses the cyclic movement of the ball between the nut and the screw to move the load. T-shape screw uses the oil film between the nut and the screw to generate relative sliding to move the load.

Screw type	Friction form	Friction coefficient	Transmission efficiency	Self-locking force	Motor speed
Ball screw	Rolling friction	Small	High	No	High
T-shape screw	Sliding friction	Large	Low	Has a certain selflocking force	Speed limit 300rpm

## ■ Model Selection

- 1 Determine the load specifications and stroke  
 Dimension and weight of workpieces and loads, also the motion range of workpieces
- 2 Determine the static stress condition of the loads according to its installation. Eg.  
 eg: Calculate gravity and friction if installed vertically.  
 Calculate friction if installed horizontally.  
 Other forces should be considered as well.
- 3 Select the proper size of linear screw motor based on speed and the screw specifications table.  
 Estimate static torque based on static stress condition of the system.  
 Estimate dynamic torque based on accelerated speed and inertia  
 Approximately determine the condition of the motor body and screw lead.  
 (Remarks: the transmission efficiency of ACME screw is 20%-60%)
- 4 Select the matching drive

	EtherCAT	Modbus RTU	CANopen
Fieldbus type			
Pluse type			
Switching type			

## | Matching Cables

### ■ Stepper Encoder Cable



B1-030

EB+	EB-	EA+	EA-	VCC	GND
GRN	YEL	BRN	WHT	RED	BLU

Matching products: ED series closed-loop stepper motor



C1-030

EB+	EB-	EA+	EA-	VCC	GND
GRN	YEL	BRN	WHT	RED	BLU

Matching products: EC series closed-loop stepper motor

### ■ Z Signal Encoder Extension Cable



CES8-030

EB+	EB-	EA+	EA-
GRN	GRN&BLK	BLU	BLU&BLK
VCC	GND	EZ+	EZ-
RED	BLK	YEL	YEL&BLK

Matching products: ECZ series closed-loop stepper motor

### ■ Stepper Motor Power Extension Cable



C2-030 (Optional)

A+	A-	B+	B-
RED	BLU	GRN	BLK

Matching products: Stepper series

### ■ Network Cable (Short)

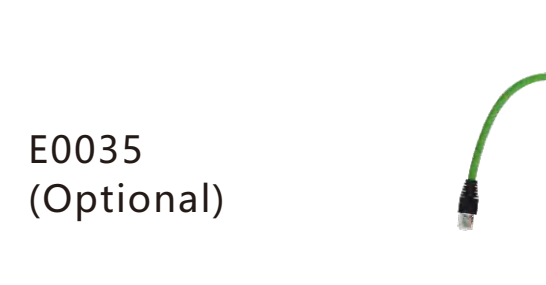

E0035 (Optional)

Matching products: EtherCAT series

### ■ RS232 Interface Tuning Cable



RS232 (Optional)

Matching products: T42,T60,T86,R60X3,R130,3R130

# | Common Model Quick Selection Table

## ■ Open Loop Stepper Drive

Model	Matching motor*	Control mode	Power supply voltage	External debug interface	Notes
R28S	28 series open loop	Pulse control	18-48VDC	TTL	
R42S	42 series open loop	Pulse control	18-48VDC	TTL	
R57-HV	57 series open loop	Pulse control	20-80VAC/18-110VDC	-	
R60S	60 series open loop	Pulse control	18-50VDC	TTL	
R60-C	60 series open loop	Pulse control	18-50VDC	-	Economic type
R60-1M	60 series open loop	Pulse control	18-50VDC	-	Pulse bandwidth 1M
R60-AL	60 series open loop	Pulse control/IO control	18-50VDC	microUSB	24V pulse only
R60-AL-5V	60 series open loop	Pulse control/IO control	18-50VDC	microUSB	5V pulse only
R85	86 series open loop	Pulse control	20-60VAC/24-80VDC	-	
R86S	86 series open loop	Pulse control	20-80VAC/28-110VDC	TTL	
R86mini	86 series open loop	Pulse control/IO control	18-80VAC/24-100VDC	microUSB	
R110PLUS v3.0	86/110 series open loop	Pulse control/IO control	110-220VAC	TTL	Dial to match motor parameters
R130	130 series open loop	Pulse control	110-220VAC	RS232	
3R60	3 phase 60 series open loop	Pulse control	18-50VDC	-	
3R110PLUSv3.0	3 phase 86/110 series open loop	Pulse control	110-220VAC	TTL	Dial to match motor parameters
3R130	3 phase 130 series open loop	Pulse control	110-220VAC	RS232	
R42IOS	42 series open loop	Pulse control/IO control	18-50VDC	TTL	
R60IOS	60 series open loop	Pulse control/IO control	18-50VDC	TTL	
R86IOS	86 series open loop	Pulse control/IO control	20-80VAC/28-110VDC	TTL	
R110PLUS-IO	110 series open loop	IO control	110-220VAC	microUSB	
R130-IO	130 series open loop	IO control	110-220VAC	RS232	
R42IRS	42 series open loop	Potentiometer/IO/Pulse control	18-50VDC	TTL	Potentiometer speed regulation
R60IRS	60 series open loop	Potentiometer/IO/Pulse control	18-50VDC	TTL	
R86IRS	86 series open loop	Potentiometer/IO/Pulse control	20-80VAC/28-110VDC	TTL	
R42-D	42 series open loop	IO control	18-50VDC	-	One Drive Two
R60-D	60 series open loop	IO control	18-50VDC	-	
R60-IRD	60 series open loop	IO control	18-50VDC	-	
R42X2	42 series open loop	Pulse control	18-50VDC	-	Biaxial, 24V pulse only
R42X2-5V	42 series open loop	Pulse control	18-50VDC	-	Biaxial, 5V pulse only
R60X2 v4.0	60 series open loop	Pulse control	18-50VDC	-	Biaxial, 24V pulse only
R60X2-5V v4.0	60 series open loop	Pulse control	18-50VDC	-	Biaxial, 5V pulse only
R60X3 v4.0	60 series open loop	Pulse control	18-50VDC	-	Triaxial
NT60	60 series open loop	Pulse control/IO/RS485	18-50VDC	RS485	
NT86	86 series open loop	Pulse control/IO/RS485	18-80VAC/24-110VDC	RS485	
NT60-C	60 series open loop	CANopen	18-50VDC	RS485	
NT86-C	86 series open loop	CANopen	18-80VAC/24-110VDC	RS485	
EPR60	60 series open loop	TCP	18-50VDC	TCP/IP	
ECR42	42 series open loop	EtherCAT	18-80VDC	EtherCAT	
ECR60	57/60 series open loop	EtherCAT	18-80VDC	EtherCAT	
ECR60X2A	57/60 series open loop	EtherCAT	18-80VDC	EtherCAT	Biaxial
ECR60X2A-S	57/60 series open loop	EtherCAT	18-80VDC	EtherCAT	Dual axis synchronization
ECR86S	86 series open loop	EtherCAT	20-80VAC/28-110VDC	Type-C	

## ■ Open Loop Stepper Motor

Motor base	Model	Rated torque (N.M)	Rated current (A)	Matching drive	Shaft diameter* (mm)	Shaft length (mm)	Length (mm)	Notes
20	20AM003	0.03	0.6	R42	G4	10	33	
	20AM005	0.05	0.6		G4	10	45	
28	28AM006	0.06	1.2		D5	20	32	
	28AM01	0.10	1.2		D5	20	41	
	28AM013	0.13	1.2		D5	20	51	
35	35A02	0.2	1.0		D5	20	34	
39	39A02	0.2	1.0		D5	20	36	
42	42AM02	0.2	1.5		D5	24	34	
	42AM04	0.4	1.5		D5	24	40	
	42AM06	0.6	2.0		D5	24	47	
	42AM06-Z2	0.6	2.0	D5	24	78	Brake	
	42AM08	0.8	2.0	D5	24	60		
	42AM08-Z2	0.8	2.0	D5	24	91	Brake	
	42A01	0.15	1.0	D5	24	34		
	42A02	0.2	1.2	D5	24	40		
	42A03	0.3	2.0	D5	24	47		
	42A08	0.8	2.0	D5	24	60		
57	57AM13	1.3	3.0	D8	21	55		
	57AM13-6.35	1.3	3.0	D6.35	21	55		
	57AM23	2.3	5.0	D8	21	76		
	57AM23-6.35	2.3	5.0	D6.35	21	76		
	57AM24	2.4	5.6	D8	21	80		
	57AM24-Z2	2.4	5.6	D8	21	124	Brake	
	57AM26	2.6	5.0	D8	21	84		
	57AM30	3.0	5.0	D8	21	102		
	57AM30-Z2	3.0	5.0	D8	21	146	Brake	
	57A09	0.9	2.8	D6.35	21	55		
	57A09-8	0.9	2.8	D8	21	55		
	57A1	1.3	2.8	D6.35	21	76		
	57A1-8	1.3	2.8	D8	21	76		
D57	57A1S8D	1.3	2.8	D8	21	76	Biaxial	
	57A2	2.2	4.0	D8	21	80		
	57A3	3.0	5.0	D8	21	102		
	D57AM30	3.0	5.0	D8	21	86		
	60	60AM21	2.1	5.0	D8	21	58	
		60AM30	3.0	5.0	D8	21	86	
		60AM30-Z2	3.0	5.0	D8	21	125	Brake
60AM40		4.0	5.0	D10	30	102		

\*G-Plain shaft, D-Single flat, K-Keyed

### Open Loop Stepper Motor

Motor base	Model	Rated torque (N.M)	Rated current (A)	Matching drive	Shaft diameter* (mm)	Shaft length (mm)	Length (mm)	Notes
86	86AM35	3.5	4.0	R86	D9.5	32	64	
	86AM45	4.5	6.0		D12.7	32	78	
	86AM45-14	4.5	6.0		K14	32	78	
	86AM45-Z2	4.5	6.0		K14	32	123	Brake
	86AM65	6.5	6.0		K12.7	32	98	
	86AM65-14	6.5	6.0		K14	32	98	
	86AM85	8.5	6.0		K12.7	32	112	
	86AM85-14	8.5	6.0		K14	32	112	
	86AM85-Z2	8.5	6.0		K14	32	157	Brake
	86AM100	10	6.0		K14	32	128	
	86AM120	12	6.0		K15.875	32	155	
	86AM120-14	12	6.0		K14	32	155	
	86AM120-Z2	12	6.0		K14	32	199	Brake
	110	110A12	12		6.0	R110PLUS	K19	56
110A20		20	6.0	K19	56		150	
110A28		28	6.5	K19	56		201	
130	130A27	27	6.0	R130	K19	45	226	
	130A45	45	7.0		K19	45	283	

\*G-Plain shaft, D-Single flat, K-Keyed

### Closed Loop Stepper Drive

Model	Matching motor*	Control mode	Power supply voltage	External debug interface	Notes
T42S	42 series closed loop	Pluse control	18-50VDC	TTL	
T60S	57/60 series closed loop	Pluse control	18-50VDC	TTL	
T60-IO	60 series closed loop	IO control	18-50VDC	RS232	
T60-1M	60 series closed loop	Pluse control	18-50VDC	RS232	Pulse bandwidth 1M
T60PLUS v3.0	60 series closed loop	Pluse control	18-50VDC	mini USB	Z signal interface
T86S	86 series closed loop	Pluse control	18-80VAC/24-100VDC	TTL	
T86-IO	86 series closed loop	IO control	18-80VAC/24-100VDC	RS232	
3T60	3 phase 60 series closed loop	Pluse control	18-50VDC	RS232	
3T60PLUS v3.0	3 phase 60 series closed loop	Pluse control	18-50VDC	mini USB	Z signal interface
NT60	60 series closed loop	Pluse control/IO control/RS485	18-50VDC	RS485	
NT86	86 series closed loop	Pluse control/IO control/RS485	18-80VAC/24-100VDC	RS485	
NT60-C	60 series closed loop	CANopen	18-50VDC	RS485	
NT86-C	86 series closed loop	CANopen	18-80VAC/24-110VDC	RS485	
DS86	86 series closed loop	Pluse control	20-80VAC/24-110VDC	Type-C	
EPT60	60 series closed loop	TCP	18-50VDC	TCP/IP	
ECT42	42 series closed loop	EtherCAT	18-80VDC	EtherCAT	
ECT60	57/60 series closed loop	EtherCAT	18-80VDC	EtherCAT	
ECT60X2	57/60 series closed loop	EtherCAT	18-80VDC	EtherCAT	Biaxial
ECT60X2-S	57/60 series closed loop	EtherCAT	18-80VDC	EtherCAT	Dual axis synchronization
ECT86	86 series closed loop	EtherCAT	18-80VAC/24-100VDC	EtherCAT	
EST60	60 series closed loop	EtherCAT	20-80VDC/18-50VAC	Type-C	
EST60X2	60 series closed loop	EtherCAT	20-80VDC/18-50VAC	Type-C	Biaxial
EST60X4	60 series closed loop	EtherCAT	20-80VAC	Type-C	Four axis

\*The matching motor specification is for reference only, smaller motor is also compatible.

### Closed Loop Stepper Motor

Motor base	Model	Rated torque (N.M)	Rated current (A)	Matching drive	Extension cord*	Shaft diameter* (mm)	Shaft length (mm)	Length (mm)	Notes	
20	20AM003EC	0.03	0.6	T42	Encoder cable C1-030	G4	20	46		
28	28AM006EC	0.06	1.2			D5	20	45		
	28AM013EC	0.13	1.2			D5	20	64		
42	42A03EC	0.3	2.0	T42	Power cable C2-030**	D8	21	69		
	42A08EC	0.8	2.8			D8	21	85		
	42AM06ED	0.6	2.0			Encoder cable B1-030	D5	24	67	
	42AM06ED-Z2	0.6	2.0				D5	24	98	Brake
	42AM06ED-8	0.6	2.0				D8	24	67	
	42AM08ED	0.8	2.0			Power cable C2-030**	D5	24	79	
	42AM08ED-Z2	0.8	2.0				D5	24	110	Brake
	42AM08ED-8	0.8	2.0				D8	24	79	
42AM08ED-8-Z2	0.8	2.0	D8	24	110		Brake			
57	57AM13ED	1.3	4.0	T60	Encoder cable B1-030	D8	22	77		
	57AM23ED	2.3	5.0			D8	22	98		
	57AM24ED-Z2	2.3	5.0			D8	22	142	Brake	
	57AM26ED	2.6	5.0			D8	22	106		
	57AM30ED	3.0	5.0			D8	22	124		
	57AM30ED-Z2	3.0	5.0			D8	22	168	Brake	
D57	D57AM30ED	3.0	5.0	T60	Power cable C2-030**	D8	22	107		
60	60AM22ED	2.2	5.0			D8	22	79		
	60AM30ED	3.0	5.0			D8	22	107		
	60AM30ED-Z2	3.0	5.0			D8	22	150	Brake	
86	60AM40ED	4.0	5.0	T86	Encoder cable B1-030	D10	30	123		
	86AM45ED	4.5	6.0			K14	40	105		
	86AM45ED-Z2	4.5	6.0			K14	40	151	Brake	
	86AM65ED	6.5	6.0			K14	40	127		
	86AM85ED	8.5	6.0			Power cable C2-030**	K14	40	140	
	86AM85ED-Z2	8.5	6.0				K14	40	185	Brake
	86AM100ED	10	6.0				K14	40	157	
	86AM120ED	12	6.0			K14	40	182		
86AM120ED-Z2	12	6.0	K14	40	228	Brake				
42	42AM06ECZ	0.6	2.0	T60PLUS	Encoder cable CES8-030	D5	24	67	Z signal	
	42AM08ECZ	0.8	2.0			D5	24	79		
	51A1ECZ	1.3	4.0			D8	22	76		
57	57A2ECZ	2.0	3.5	T60PLUS	Encoder cable CES8-030	D8	22	98		
	57A3ECZ	3.0	5.0			D8	22	123		
60	60A3ECZ	3.0	5.0	T60PLUS	Power cable C2-030**	D8	22	110		
	86AM45ECZ	4.5	6.0			K14	40	105		
86	86AM100ECZ	10	6.0	T86	Power cable C2-030**	K14	40	157		
	86A12ECZ	12	6.0			K14	40	176		

\*The standard length of the extension cable is 3 meters, if you need other sizes, please specify when ordering

\*\*Power cable C2 is an optional model, if necessary, please specify when ordering

\*\*\*G-Plain shaft, D-Single flat, K-Keyed

## | Cooperative Partners



## | Industry & Application



## | Marketing & Sales network

